

WILDFIRE

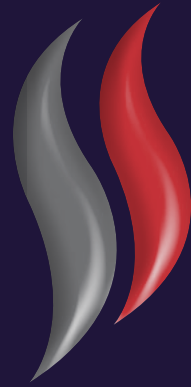

GAS & ELECTRIC APPLIANCES 2022/23

Exquisite fires for elegant homes

Contents

All about Wildfire..... 4-5

Gas Fires

Some things you need to know..... 6-7

Function and Performance..... 8-9



High Efficiency
(Glass Fronted)
Gas Fires

Ravel 1500 Media Suite (Balanced Flue)..... 10-11
for homes with no flue

Ravel 1720 Media Suite (Balanced Flue)..... 12-13
for homes with no flue

HE900 (Avellino Suite)..... 14-15
for standard and precast flues

HE950L (Seville Suite)..... 16-17
for standard and precast flues

Ravel 600 (Asti 600 Suite) Limestone..... 18-19
for standard flues

Ravel 600 (Amalfi Suite) Micro Marble 20-21
for standard flues

Ravel 600 HIW Gas Fire..... 22-23
for standard flues

Ravel 800 (Asti 800 Suite) Limestone..... 24-25
for standard flues

Ravel 800 (Siena Suite) Micro Marble..... 26-27
for standard flues

Ravel 800 (HIW)..... 28-29
for standard flues

Ravel 750 (Asti 750 Suite) Limestone..... 30-31
for standard flues

Ravel 750 (Valentia Suite) Micro Marble 32-33
for standard flues



High Efficiency
(Glass Fronted)
Gas Fires

Panama HE (Salvador Suite)..... 34-35
for standard flues

Cressida HE..... 36-37
for standard flues

Pesaro HE slimline..... 38-39
for standard and precast flues

Ravel 400 HE (Salvador Suite)..... 40-41
for standard flues

Ravel 400 Inset Stove (Salvador Suite)..... 42-43
for standard flues

Ravel 400 HE (HIW)..... 44-45
for standard flues

Ravel 400 HE (Balanced Flue) 46-47
for homes with no flue

Thermes (Balanced Flue) 48-49
for homes with no flue

BF960SL (Balanced Flue) 50-51
for homes with no flue



Open Fronted
Gas Fires

Cavello..... 52-53
Full Depth Open Fronted for standard flues

Montese (Cadiz Suite)..... 54-55
Radiant full Depth Open Fronted for standard and precast flues

Ceralis (Salerno suite) 56-57
Radiant Open Fronted for standard & precast flues

Ellipsis (HIW / Hearth Mount)..... 58-59
A range of options featuring the Ellipsis trim



Gas Stoves

Ravel Gas Stove
for standard and precast flues..... 60-61



Trim Options
& Technical
Information
for Gas Fires

Trim Options..... 62
Choose a trim for your Gas Fire

Technical information
for all gas appliances..... 63

Electric Fires

Some things you need to know..... 64-65



Electric
Fireplace
Suites

HE900E (Avellino Suite) 66-67
for Flat Wall installation

HE950LE (Seville Suite) 68-69
for Flat Wall installation

Panama E22 (Salvador Suite)..... 70-71
Widescreen Electric Fireplace

Ravel E16 (Salvador Suite) 72-73
16x22 Electric Fireplace



Trim Options
& Technical
Information for
Electric Fires

Trim Options..... 74
Choose a trim for your Electric Fire

Fireplace dimensions for all
Electric Fireplace Suites..... 75

Exquisite fires for elegant homes

Wildfire are a multi award winning gas appliance manufacturer.

The HE950L Seville Suite was named not only Gas fireplace suite of the year, but also 'Product of the Year' at the 2018 Hearth and Home exhibition.

Wildfire are dedicated to the design and manufacture of innovative and attractive fireplaces for British homes. At Wildfire we are committed to providing the highest quality heating products with a proven performance. Our innovative range of gas and electric fireplace suites have been tested to comply with the latest British and European standards and are manufactured in an ISO certified factory.



HE950L Seville Suite



New for the 2022/2023 are the Ravel 400 balanced flue and the impressive 1500 & 1720 Ravel media wall fires. Contact your dealer for a demonstration.

The Wildfire gas product range includes many products which have been designed and approved with efficiency at their core. In a world where energy costs have soared we believe it is important to obtain the absolute maximum from your heating appliance.

With this in mind the net efficiency of Wildfire open fronted gas fires are up to 62% and the glass fronted fires up to 87.2%. So when you purchase a Wildfire heating product you can be confident that you will be installing a product that will deliver in all installation scenarios. Here at Wildfire we are devoted to innovative design whilst maintaining maximum functionality. All Wildfire slide control gas fires feature the latest patented Direct Slide technology.

Wildfire is the premier gas and electric appliance brand from Hearth Products Limited. Hearth Products has been actively involved in design and technology for the fireplace industry across the globe since 2003. Our product technologies have been used in products across Europe, Australia and North America.

See full details of our product range at either www.wildfiregas.co.uk or www.wildfireelectric.co.uk

Some things you need to know

Do I need a Convector or a Radiant Gas Fire?

It is important to know the difference between Radiant heat and Convected heat.

Radiant heat. In short, Radiant heat is emitted from all Wildfire appliances. This type of heat is actually infrared and heats objects in the room. Radiant heat is considered to be the most comfortable and natural form of heat.

Convected heat warms the air in the room. By passing the cooler air which enters the appliance at the bottom, through a heat exchanger, it warms up, then emits the hotter air back into the room from the top of the appliance.

Do I need a Glass Fronted Gas Fire?

A glass fronted fire will be more efficient and therefore more cost effective to run. Glass fronted appliances are usually more expensive to buy.

In general terms, it is usually more cost effective to purchase a glass fronted appliance if it is to be used more regularly as the efficiency savings will provide a quicker payback for the more expensive appliance. It is also important to remember that a glass fronted appliance will normally provide a similar amount of heat to an open fronted appliance, however, as it is more efficient, it is cheaper to run.



We guarantee* our gas fire products for a period of 5 years from installation and our customer service staff are always on hand to help you with any query you may have with your product.

Our 5 year limited guarantee* is managed directly by Wildfire through our extensive network of service centres throughout the UK. Choose Wildfire for style, performance, reliability, value and peace of mind.



Brick Chimney



Pre-Fabricated



Pre-Cast

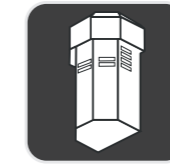

Balanced Flue

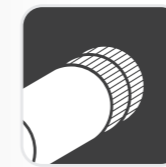

Balanced Flue



Manual Control



Slide Control



Manual Electronic Control



Natural Gas

What type of flue do I have?

You will need to know what type of flue you have in your home. You will see these icons on each product page which will show if the appliance is suitable for your property. It may be that you have a Brick Chimney (otherwise known as a Class 1 flue), a Pre-Fabricated Metal System (which can be a Class 1 or Class 2 flue) or a Pre-Cast Flue (a flue which is built into the inner brickwork of your home). If you do not have a chimney or flue system in your home then you will need to look for a balanced flue gas fire which, if you already have a balanced flue gas fire in the property, is usually indicated by a flue terminal concealed within a basket on the outside of the property.

What control options are available?

All Wildfire products are available with a Direct Slide option giving you the ease of reliable and simple operation. The slide control provides ignition, flame control and turns the fire off when you're finished. Most of the Wildfire range is available in manual control too — these fires have a removable cover at the base of the fire where the rotary control and igniter are situated.

Wildfire have now introduced electronic ignition on the majority of the manual control range.

What type of gas do I need?

Wildfire appliances are currently only available for natural gas.

Function & Performance

O.D.S

The Oxygen Depletion Sensor will automatically shut off the gas supply to the burner if the oxygen level in the room falls below a particular level. This is important as it will turn off the appliance should the flue become blocked or a lack of ventilation occurs.

F.S.D

The Flame Supervision Device is designed to sense the presence of a flame. Should the flame be extinguished for any reason then the safety device will cut off the supply of gas to the burner.

Optional Ezi-Grip Handle



Most Wildfire appliances can be fitted with an elderly/infirm handle to ease the lighting operation. This larger handle is much easier to access and move so if you think that this may be a requirement then talk to your retailer who will demonstrate the Ezi-Grip system. This handle is purchased as an accessory and is fitted at the point of installation of the appliance.

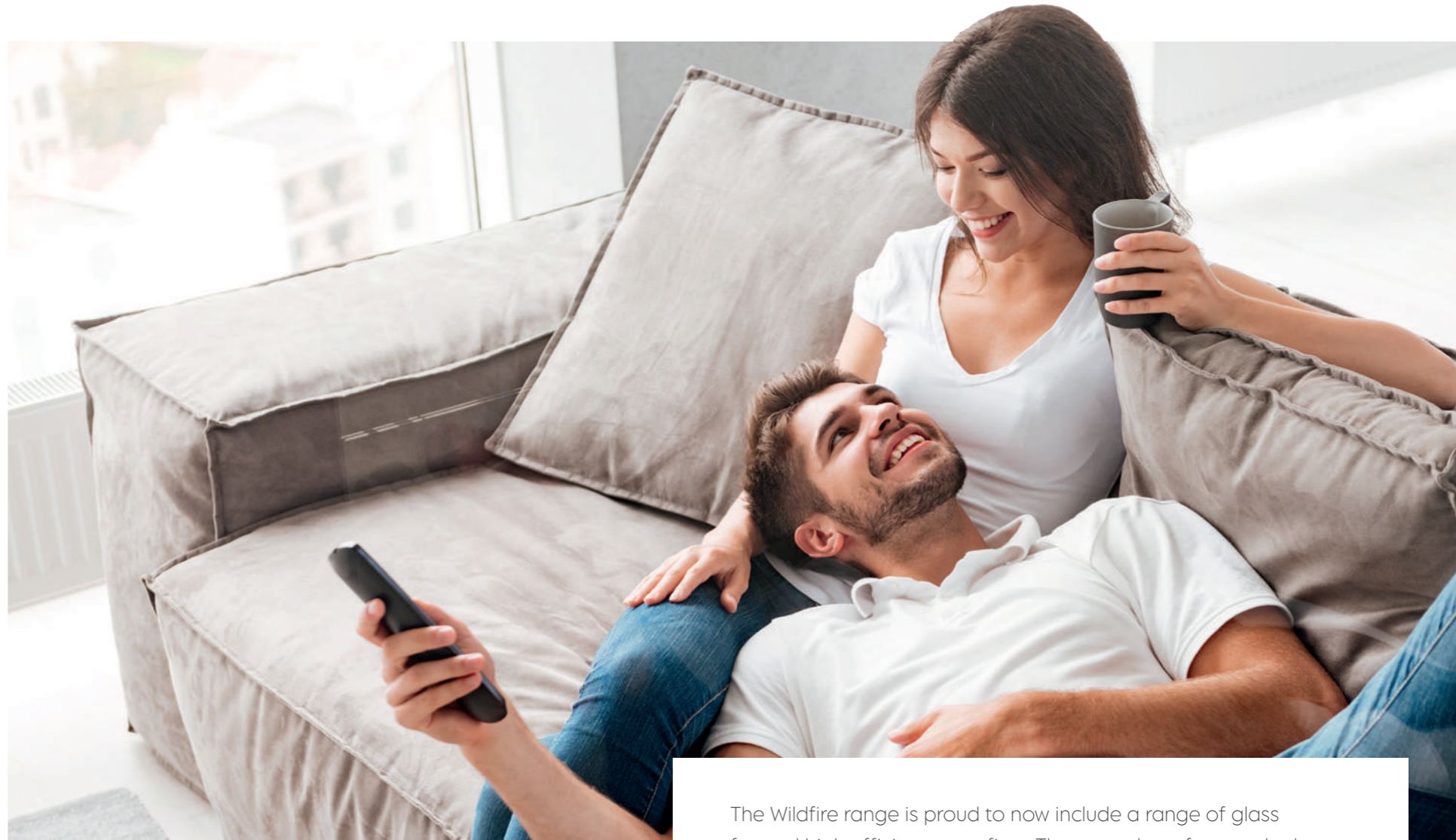

The Wildfire range is proud to now include a range of glass fronted high efficiency gas fires. These products feature the latest technology in high output gas fires and deliver the most effective way of heating your living room. The range includes both mid-depth convector and full depth convector products, both available with Direct Slide Technology. The Ravel 400 appliance can also be installed into a hole in the wall by fitting the 4 sided HIW trim (See pages 44 and 45). The balanced flue gas fires are a high efficient appliance solution for homes with no chimney, the Thermes & Ravel 400 BF deliver heat, value for money, efficiency and are available with a large range of trim options.



Open fronted appliances are designed to operate with the revolutionary XE system which is only available from Hearth Products. This new efficiency system is designed to 'tune' the appliance to your fireplace flue, thereby ensuring you obtain the maximum output from the appliance.

Regulations demand that gas fires must be installed by a Registered Gas Safe Engineer. For further information regarding Gas Safe requirements contact Wildfire directly, where we will be happy to give you advice. Warranty will be void if the appliance is not fitted in accordance to these legal requirements.



RAVEL 1500 Media Wall

Balanced Flue



The Ravel 1500 MW fire provides an astonishing solution for a gas media wall.

This balanced flue appliance will provide the heart to your media wall. With impressive heat and an unrivalled flame picture, the fuel bed is intricately detailed to reveal the perfect log fire. A convection system forces cooler air through the side grills and up through side outlets at the top of the chimney breast, or through a stylish linear outlet above the television. The installation allows all the unsightly cables to be concealed whilst delivering a stylish and functional media wall to your home. Spot heating with a gas appliance is the most cost effective method to heat a room, allowing the central heating boiler to be turned off for longer periods...the Ravel Media Wall fire is a powerhouse of heat.



FLUE OPTION



Balanced Flue

CONTROL



Slide

FUEL BED



Log

FUEL



Natural Gas

DIMENSIONS

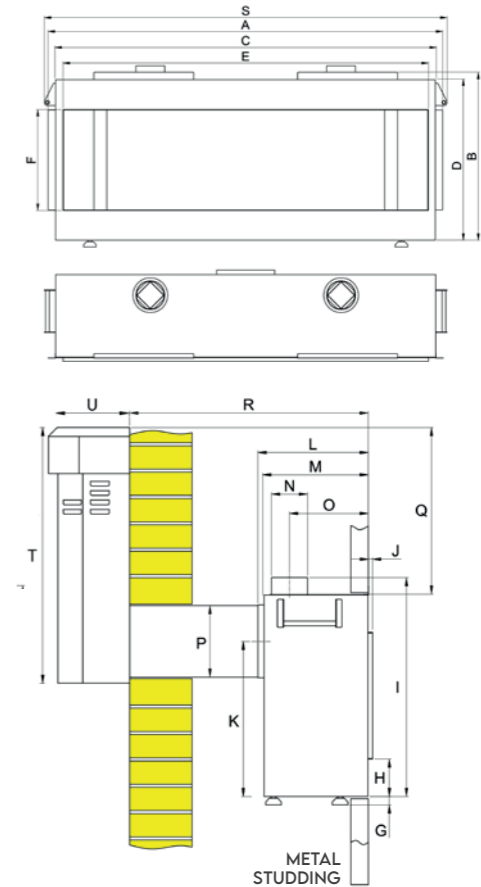

- A) 1591mm
- B) 677mm
- C) 1538mm
- D) 650mm
- E) 1473mm
- F) 407mm
- G) 27-60mm
- H) 120mm
- I) 703mm
- J) 13mm
- K) 498mm
- L) 355mm
- M) 339mm
- N) Ø116mm
- O) 253mm
- P) Ø230mm
- Q) 535mm
- R) 521-766mm
- S) 1623mm
- T) 825mm
- U) 260mm

TRIM DIMENSIONS



- A) 1481mm
- B) 415mm

GAS CONSUMPTION

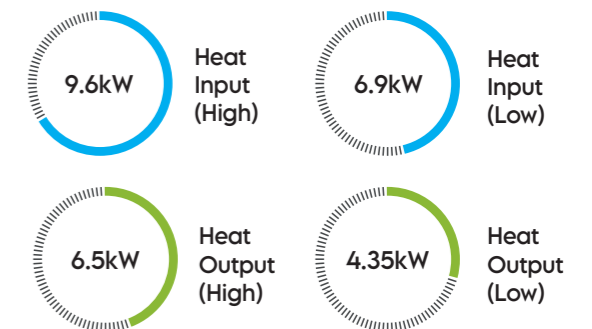

75% EFFICIENCY

RAVEL 1720 Media Wall

Balanced Flue



DIMENSIONS

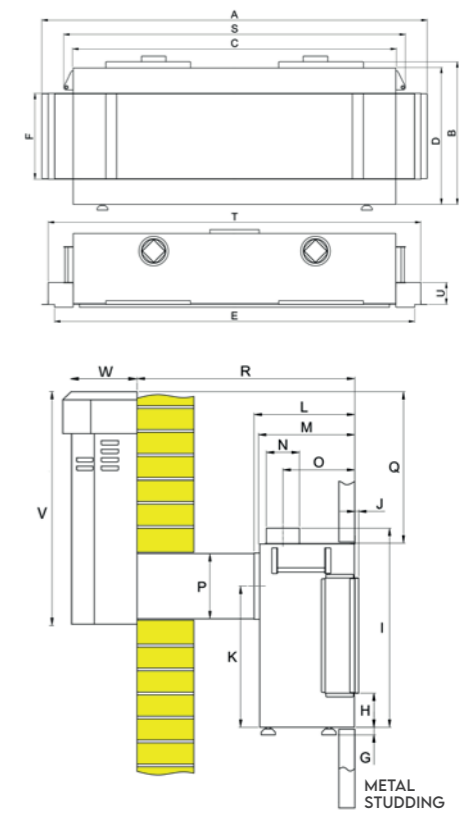

- A) 1831mm
- B) 667mm
- C) 1538mm
- D) 650mm
- E) 1711mm
- F) 407mm
- G) 27-60mm
- H) 120mm
- I) 703mm
- J) 13mm
- K) 498mm
- L) 355mm
- M) 339mm
- N) Ø116mm
- O) 253mm
- P) Ø230mm
- Q) 535mm
- R) 521-766mm
- S) 1623mm
- T) 1711mm
- U) 104mm
- V) 825mm
- W) 260mm

TRIM DIMENSIONS



- A) 1721mm
- B) 415mm

GAS CONSUMPTION

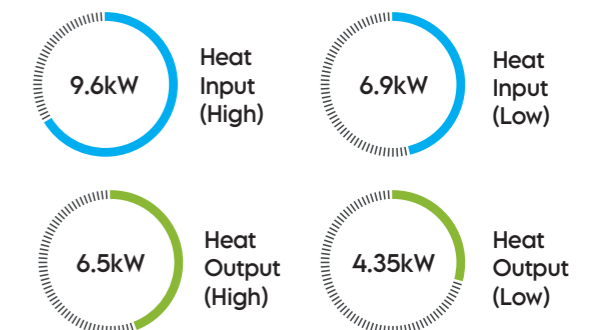

75% EFFICIENCY

The Ravel 1720 MW fire provides a wider version of the 1500MW suitable for the larger sized TV.

This balanced flue appliance will provide the heart to your media wall. With a massive heat output and an unrivalled flame picture, the fuel bed is intricately detailed to reveal the perfect log fire. A convection system forces cooler air through the side grills and up through side outlets at the top of the chimney breast, or through a stylish linear outlet above the television. The installation allows all the unsightly cables to be concealed whilst delivering a stylish and functional media wall to your home. Spot heating with a gas appliance is the most cost effective method to heat a room, allowing the central heating boiler to be turned off for longer periods...the Ravel 1720 Media Wall fire is a powerhouse of heat combined with ultra realism.



FLUE OPTION

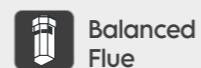

CONTROL



FUEL BED



FUEL



HE 900 | (Avellino Suite)



DIMENSIONS

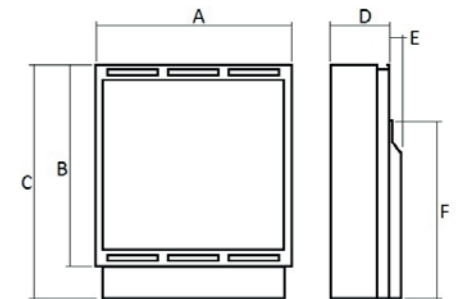

- A) 659mm D) 165mm (Standard) E) 55mm (PCF)
- B) 640mm D) 220mm (PCF) F) 553mm
- C) 740mm E) 110mm (Standard)

MANTEL DIMENSIONS

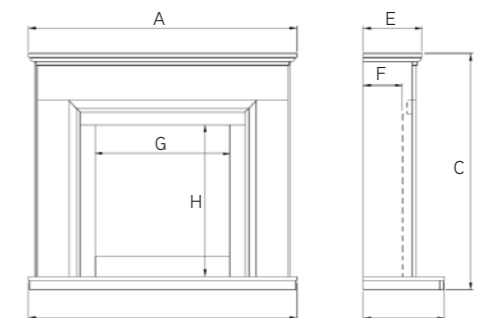

- A) 1320mm E) 235mm (Standard) G) 663mm
- B) 1320mm E) 290mm (PCF) H) 744mm
- C) 1159mm F) 165mm (Standard)
- D) 400mm F) 220mm (PCF)

The HE900 is the flagship model from Wildfire, the ultimate in fireplace technology.

The HE900 gas fire is revolutionary. It has been developed to create a European format appliance with expansive viewing glass that can be installed into a conventional 16" x 22" fireplace opening without any modification, or precast flue where the PCF version is ordered. This patent pending product is designed to fit UK fireplace openings with no need to alter the fabric of the building.

The HE900 features a stunning log and ember bed, easily controlled with a slide operating system which comes as standard. Finally, the ultimate fireplace solution has arrived...

The Avellino micro marble suite is available in white or white with grey border.



Shown as standard version. Also available for Precast Flue.

FLUE OPTIONS

- Brick Chimney
- Pre-Fabricated
- *Pre-Cast

*When ordered as PCF model

CONTROL

- Slide

FUEL BED

- Log

FUEL

- Natural Gas

GAS CONSUMPTION

83% EFFICIENCY

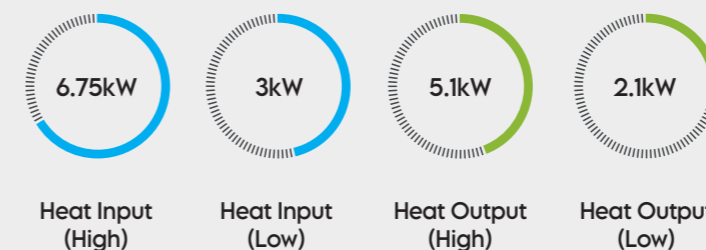

STANDARD MANTEL FINISH OPTIONS



White

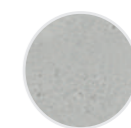

Grey

Available with grey inner border - see similar detail on the Seville Suite - page 12.

HE 950L | (Seville Suite)



HE





The new HE950L (STD & PCF) is the perfect appliance to bring your fireplace to life.

Just like the HE900, its predecessor, this fire fits into your standard 16" x 22" builders opening or precast flue if the PCF version is ordered. No building work, lintels, mess or costly installation. The fabric of your home will remain intact but you will benefit from a landscape, large format gas fire with beautifully crafted logs and colourful dancing flames. Ask your retailer for the different fireplace design options available with the HE950L, they will be able to deliver a suite to compliment the style of your living room.

FLUE OPTIONS

 Brick Chimney

 Pre-Fabricated

 *Pre-Cast

*When ordered as PCF model

CONTROL

 Slide

FUEL BED

 Log

FUEL

 Natural Gas

GAS CONSUMPTION

75% EFFICIENCY

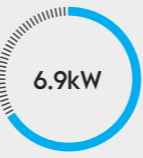

6.9kW

Heat Input (High)



3kW

Heat Input (Low)



4.6kW

Heat Output (High)

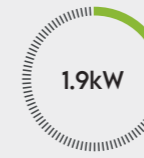

1.9kW

Heat Output (Low)

DIMENSIONS

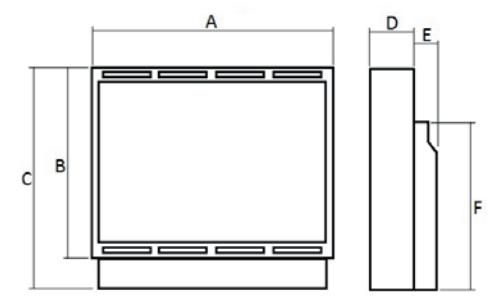

- A) 800mm D) 165mm (Standard) E) 55mm (PCF)
- B) 520mm D) 220mm (PCF) F) 553mm
- C) 620mm E) 110mm (Standard)

MANTEL DIMENSIONS

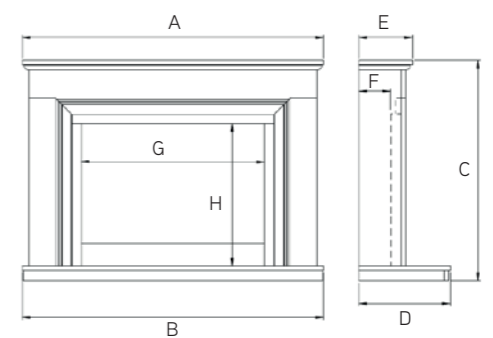

- A) 1320mm E) 235mm (Standard) G) 803mm
- B) 1320mm E) 290mm (PCF) H) 624mm
- C) 967mm F) 165mm (Standard)
- D) 400mm F) 220mm (PCF)

STANDARD MANTEL FINISH OPTIONS



RAVEL 600 | (Asti 600 Suite) Limestone



The Ravel 600 joins the family of Ravel products from Wildfire. This glass fronted gas fire is suitable for both class 1 and class 2 flues.

The Ravel 600 features the latest in under-log burner technology is sure to impress with its stunning fuel bed layout. The unique burner system allows the fire to be turned to low whilst still retaining an impressive flame picture.

Shown here in the Asti 600 Limestone surround, installed with the sleek Edge trim, for the trimless look. The Ravel 600 will fit nearly all masonry fireplace openings.



Ravel 600 Edge trim, installed into the As 600 Limestone Suite

FLUE OPTIONS

- Brick Chimney
- Pre-Fabricated

WATCH VIDEO



Scan QR Code

CONTROL

- Slide

FUEL BED

- Log

FUEL

- Natural Gas

Dimensions

EDGE

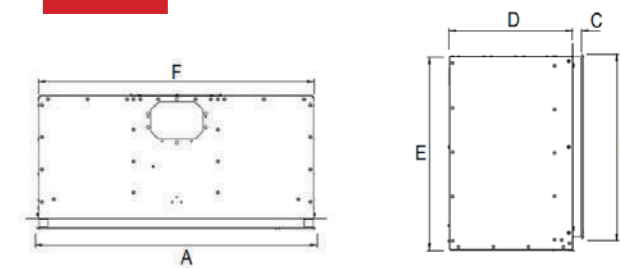

- A) 598mm
- B) 598mm
- C) 18-32mm
- D) 280mm
- E) 665mm
- F) 597mm

EDGE TRIM ONLY

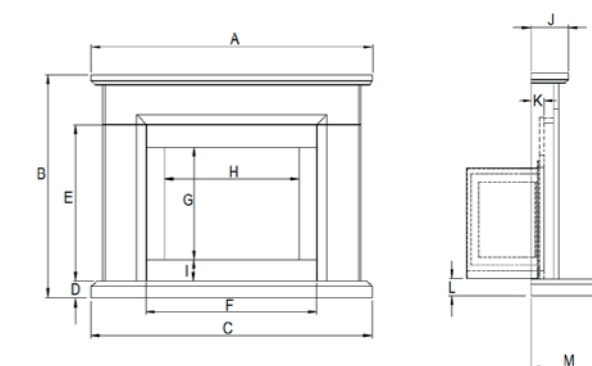

- A) 1210mm
- B) 1032mm
- C) 1220mm
- D) 60mm
- E) 742mm
- F) 780mm
- G) 590mm
- H) 588mm
- I) 72mm
- J) 145mm
- K) 45mm
- L) 60mm
- M) 380mm

Note: The Asti 600 Limestone suite is only available to suit the Edge style trim as shown.

GAS CONSUMPTION

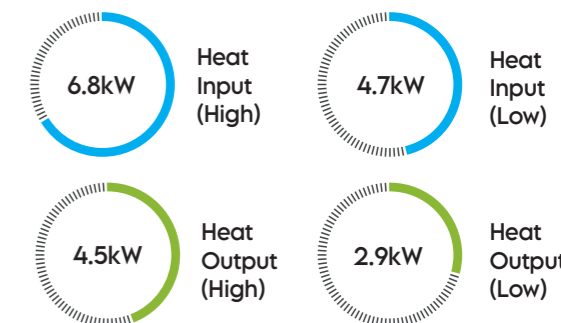

74% EFFICIENCY

RAVEL 600

(Amalfi Suite) Micro marble



The Ravel 600 joins the family of Ravel products from Wildfire. This glass fronted gas fire is suitable for both class 1 and class 2 flues.

The Ravel 600 features the latest in under-log burner technology is sure to impress with its stunning fuel bed layout. The unique burner system allows the fire to be turned to low whilst still retaining an impressive flame picture.

Shown here in the Amalfi 600 micro marble surround, installed with the sleek Edge trim, for the trimless look. The Ravel 600 will fit nearly all masonry fireplace openings.



Ravel 600 Edge trim, installed into the Amalfi 600 micro marble Suite

FLUE OPTIONS

- Brick Chimney
- Pre-Fabricated

WATCH VIDEO



Scan QR Code

CONTROL

- Slide

FUEL BED

- Log

FUEL

- Natural Gas

Dimensions

EDGE

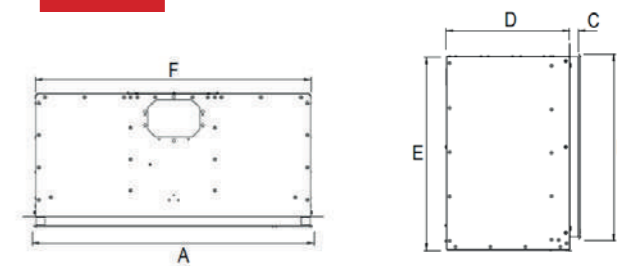

- A) 598mm
- B) 598mm
- C) 18-32mm
- D) 280mm
- E) 665mm
- F) 597mm

EDGE TRIM ONLY

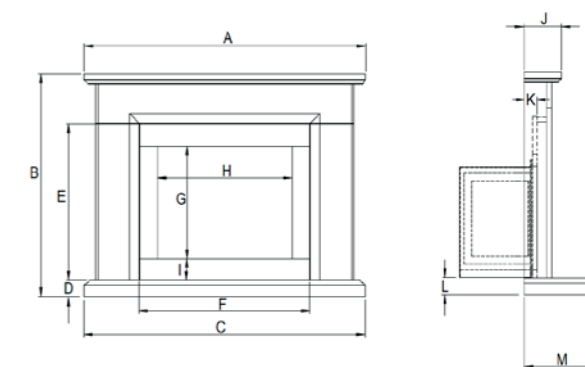

- A) 1210mm
- B) 1032mm
- C) 1220mm
- D) 60mm
- E) 742mm
- F) 780mm
- G) 590mm
- H) 588mm
- I) 72mm
- J) 145mm
- K) 45mm
- L) 60mm
- M) 380mm

Note: The Amalfi marble suite is only available to suit the Edge style trim as shown.

GAS CONSUMPTION

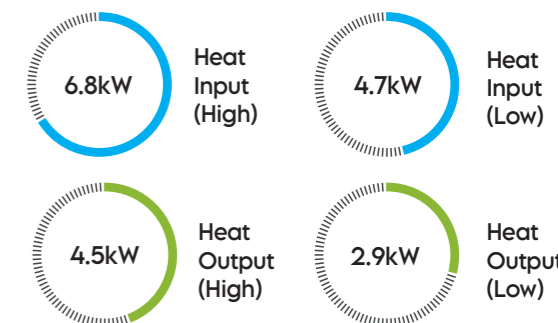

74% EFFICIENCY

RAVEL 600 | HIW Gas Fire



HE

Ravel 600 Edge trim, installed as HIW. Inset: Ravel 600 shown with standard (wide) trim.



The Ravel 600 joins the family of Ravel products from Wildfire. This glass fronted gas fire is suitable for both class 1 and class 2 flues.

The Ravel 600 features the latest in under-log burner technology is sure to impress with its stunning fuel bed layout. The unique burner system allows the fire to be turned to low whilst still retaining an impressive flame picture.

Shown here installed as a Hole in the Wall fire with the sleek Edge trim, for the trimless look. The Ravel 600 will fit nearly all masonry fireplace openings.

FLUE OPTIONS

- Brick Chimney
- Pre-Fabricated

WATCH VIDEO



Scan QR Code

CONTROL

- Slide

FUEL BED

- Log

FUEL

- Natural Gas

Dimensions

EDGE

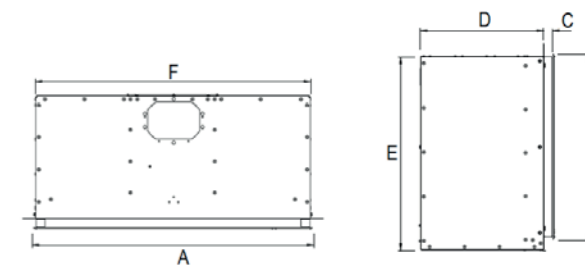

- A) 598mm
- B) 598mm
- C) 18-32mm
- D) 280mm
- E) 665mm
- F) 597mm

STANDARD

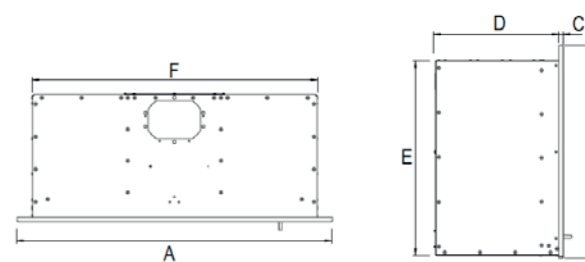

- A) 747mm
- B) 747mm
- C) 10mm
- D) 280mm
- E) 665mm
- F) 597mm

GAS CONSUMPTION

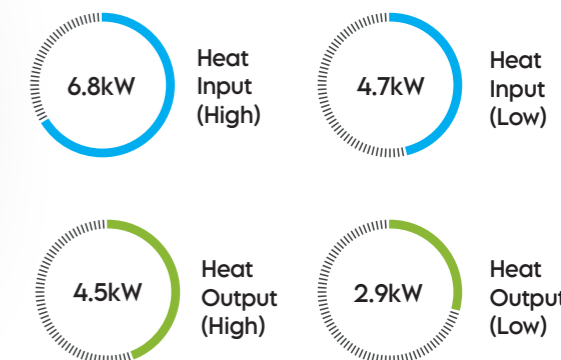

74% EFFICIENCY

RAVEL 800

(Asti 800 Suite) Limestone



Ravel 800 Edge trim, installed into the Asti Limestone Suite. (Standard trim shown inset).



The Ravel 800 is one of the most exciting developments from Wildfire. This glass fronted gas fire is suitable for both class 1 and class 2 flues.

The Ravel 800 features the latest in under-log burner technology and is sure to impress with its stunning fuel bed layout.

The unique burner system allows the fire to be turned to low whilst still retaining an impressive flame picture.

Shown here in the Asti Limestone surround, this fire is available with two trim styles, the Edge trim, for the sleek trimless look or the conventional style Standard trim.

FLUE OPTIONS

- Brick Chimney
- Pre-Fabricated

WATCH VIDEO



Scan QR Code

CONTROL



Slide

FUEL BED



Log

FUEL



Natural Gas

GAS CONSUMPTION

75% EFFICIENCY

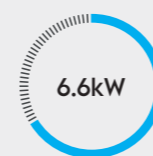

Heat Input (High)

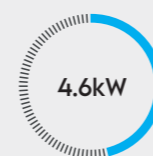

Heat Input (Low)



Heat Output (High)

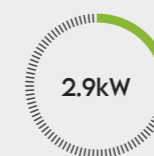

Heat Output (Low)

Dimensions

EDGE

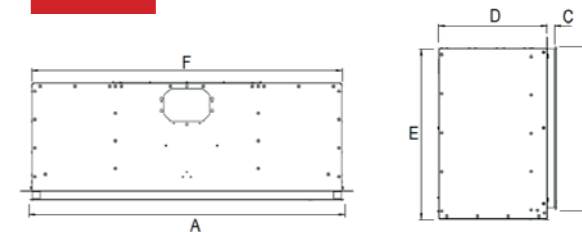

- A) 798mm
- B) 415mm
- C) 18-32mm
- D) 278mm
- E) 439mm
- F) 797mm

STANDARD

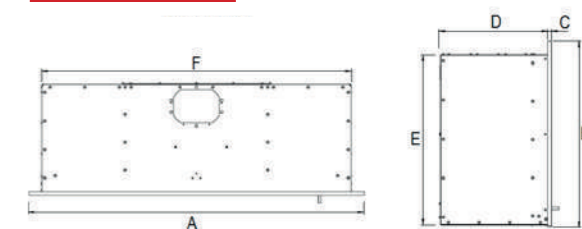

- A) 798mm
- B) 415mm
- C) 18-32mm
- D) 278mm
- E) 439mm
- F) 797mm

MANTEL DIMENSIONS

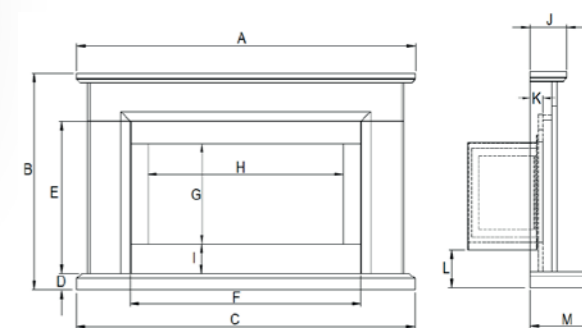

- A) 1307mm
- B) 864mm
- C) 1307mm
- D) 60mm
- E) 594mm
- F) 927mm
- J) 140mm
- K) 50mm
- L) 155mm
- M) 300mm

EDGE TRIM

- G) 406-408mm
- H) 790-792mm
- I) 124mm

STANDARD TRIM

- G) 444-446mm
- H) 806-808mm
- I) 95mm

RAVEL 800 | (Siena Suite) Micro Marble



The Ravel 800 is one of the most exciting developments from Wildfire. This glass fronted gas fire is suitable for both class 1 and class 2 flues.

Shown here in the Siena Micro marble surround, this fire is available with two trim styles, the Edge trim, for the sleek trimless look or the conventional style Standard trim.

The Ravel 800 features the latest in under-log burner technology and is sure to impress with its stunning fuel bed layout. The unique burner system allows the fire to be turned to low whilst still retaining an impressive flame picture.



Ravel 800 Edge trim, installed into the Siena Marble Suite (Standard trim shown inset).



FLUE OPTIONS

- Brick Chimney
- Pre-Fabricated

WATCH VIDEO



Scan QR Code

CONTROL



Slide

FUEL BED



Log

FUEL



Natural Gas

GAS CONSUMPTION

75% EFFICIENCY

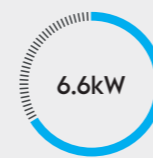

Heat Input (High)



Heat Input (Low)



Heat Output (High)



Heat Output (Low)

Dimensions

EDGE

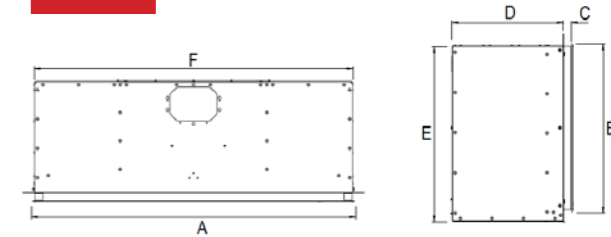

- A) 798mm
- B) 415mm
- C) 18-32mm
- D) 278mm
- E) 439mm
- F) 797mm

STANDARD

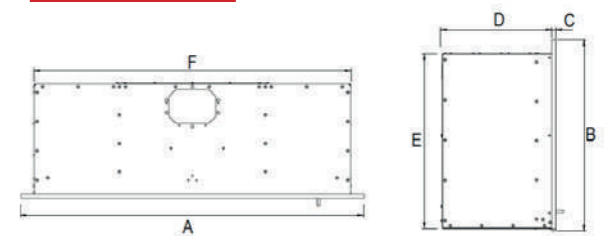

- A) 857mm
- B) 474mm
- C) 10mm
- D) 278mm
- E) 439mm
- F) 797mm

MANTEL DIMENSIONS

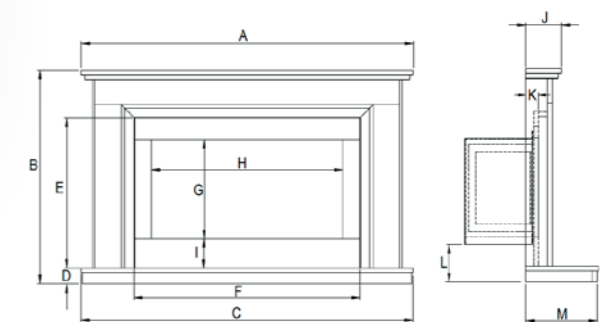

- A) 1370mm
- B) 875mm
- C) 1370mm
- D) 65mm
- E) 614mm
- F) 928mm
- J) 145mm
- K) 50mm
- L) 155mm
- M) 300mm

EDGE TRIM

- G) 406-408mm
- H) 790-792mm
- I) 119mm

STANDARD TRIM

- G) 444-446mm
- H) 806-808mm
- I) 90mm

RAVEL 800 | HIW



The Ravel 800 is one of the most exciting developments from Wildfire. This glass fronted gas fire is suitable for both class 1 and class 2 flues.

Shown here installed with the Ravel 800 Edge trim directly into a fireplace wall for a minimalistic look.

The Ravel 800 features the latest in under-log burner technology and is sure to impress with its stunning fuel bed layout. The unique burner system allows the fire to be turned to low whilst still retaining an impressive flame picture.



Ravel 800 Installed as 'Hole in the wall' with Edge trim, (Standard wider trim shown inset).



FLUE OPTIONS



Brick Chimney



Pre-Fabricated

WATCH VIDEO



Scan QR Code

CONTROL



Slide

FUEL BED



Log

FUEL



Natural Gas

Dimensions

EDGE

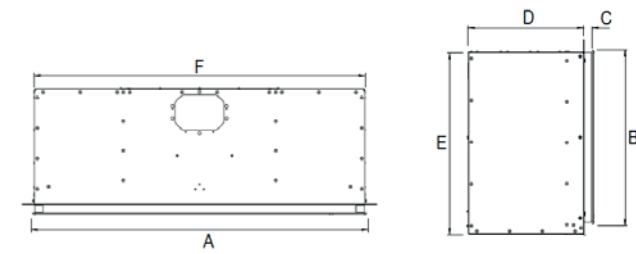

A) 798mm C) 18-32mm E) 439mm
B) 415mm D) 278mm F) 797mm

STANDARD

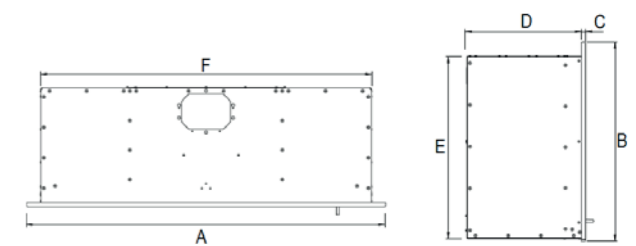

A) 857mm C) 10mm E) 439mm
B) 474mm D) 278mm F) 797mm

GAS CONSUMPTION

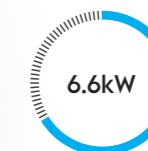

Heat Input (High)



Heat Input (Low)



Heat Output (High)

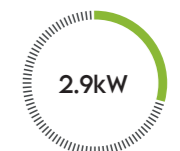

Heat Output (Low)

75% EFFICIENCY

RAVEL 750

(Asti 750 Suite) Limestone



The Ravel 750 joins the family of Ravel products from Wildfire. This glass fronted gas fire is suitable for both class 1 and class 2 flues.

The Ravel 750 features the latest in under-log burner technology is sure to impress with its stunning fuel bed layout. The graceful and ingenious burner system allows the fire to be turned to low whilst still retaining an impressive flame picture.

Shown here in the Asti 750 Limestone surround, installed with the sleek Edge trim, for the trimless look. The Ravel 750 Asti suite is the culmination of years of research, development and manufacturing excellence, producing the ultimate gas log fire.



Ravel 750 Edge trim, installed into the Asti 750 Limestone Suite. Inset: Ravel 750 shown with standard (wide) trim.



FLUE OPTIONS

- Brick Chimney
- Pre-Fabricated

WATCH VIDEO



Scan QR Code

CONTROL



Slide

FUEL BED



Log

FUEL



Natural Gas

GAS CONSUMPTION

78% EFFICIENCY

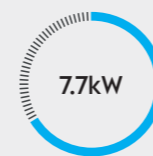

Heat Input (High)

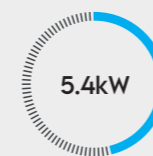

Heat Input (Low)

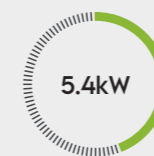

Heat Output (High)



Heat Output (Low)

Dimensions

EDGE

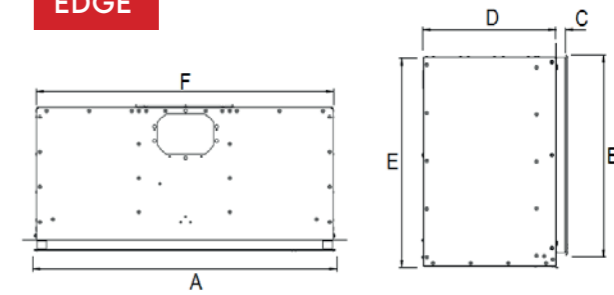

- A) 748mm
- B) 711mm
- C) 18-32mm
- D) 280mm
- E) 736mm
- F) 747mm

STANDARD

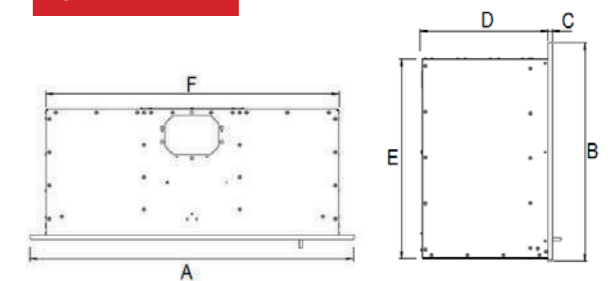

- A) 807mm
- B) 770mm
- C) 10mm
- D) 280mm
- E) 736mm
- F) 747mm

MANTEL DIMENSIONS

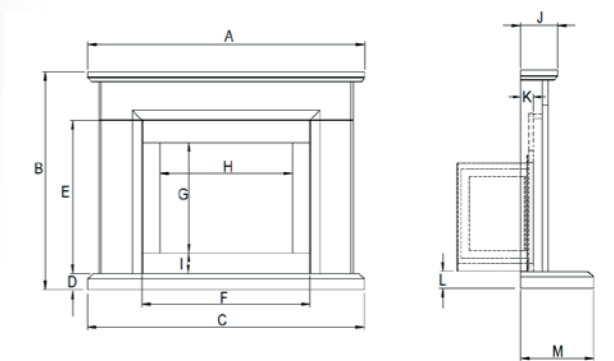

- A) 1300mm
- B) 1120mm
- C) 1280mm
- D) 60mm
- E) 820mm
- F) 840mm
- J) 160mm
- K) 45mm
- L) 100mm
- M) 380mm

EDGE TRIM

- G) 702mm
- H) 740mm
- I) 70mm

STANDARD TRIM

- G) 741mm
- H) 756mm
- I) 40mm

RAVEL 750 | (Valentia Suite) Micro Marble



The Ravel 750 joins the family of Ravel products from Wildfire. This glass fronted gas fire is suitable for both class 1 and class 2 flues.

The Ravel 750 features the latest in under-log burner technology is sure to impress with its stunning fuel bed layout. The graceful and ingenious burner system allows the fire to be turned to low whilst still retaining an impressive flame picture.

Shown here in the Valentia micro marble surround, installed with the sleek Edge trim, for the trimless look. The Ravel 750 Valentia suite is the culmination of years of research, development and manufacturing excellence, producing the ultimate gas log fire.



Ravel 750 Edge trim, installed into the Asti 750 Limestone Suite. Inset: Ravel 750 shown with standard (wide) trim.

FLUE OPTIONS

- Brick Chimney
- Pre-Fabricated

WATCH VIDEO



Scan QR Code

CONTROL



Slide

FUEL BED



Log

FUEL



Natural Gas

GAS CONSUMPTION

78% EFFICIENCY



Heat Input (High) Heat Input (Low) Heat Output (High) Heat Output (Low)

Dimensions

EDGE

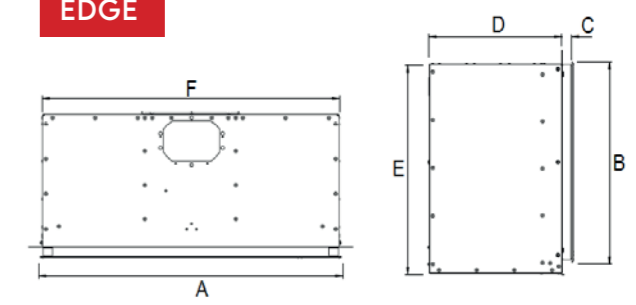

- A) 748mm C) 18-32mm E) 736mm
- B) 711mm D) 280mm F) 747mm

STANDARD

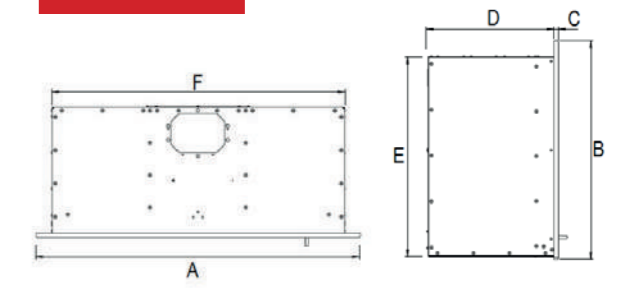

- A) 807mm C) 10mm E) 736mm
- B) 770mm D) 280mm F) 747mm

MANTEL DIMENSIONS

EDGE TRIM ONLY

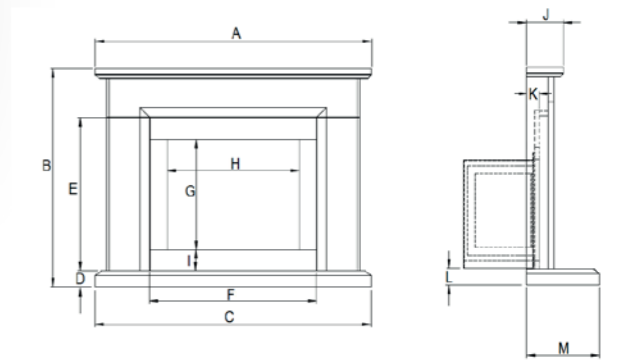

- A) 1370mm F) 928mm K) 50mm
- B) 1150mm G) 702mm L) 100mm
- C) 1370mm H) 740mm M) 300mm
- D) 65mm I) 65mm
- E) 874mm J) 170mm

Note: The Valentia marble suite is only available to suit the Edge style trim as shown.

Panama HE | (Salvador Suite)



Panama HE shown with Contemporary Chrome/Black trim, Installed into the Salvador suite in white.

This fire requires a fireplace suite with a 3" rebate and a back panel opening of a specific size. Talk to your retailer for full details.

DIMENSIONS

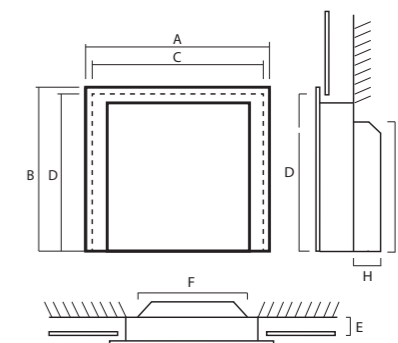

- A) 614mm Trim Width
- B) 611mm Trim Height
- C) 560mm-580mm Back Panel Opening Width
- D) 585mm-600mm Back Panel Opening Height
- E) 76mm Mantel Rebate
- F) 406mm Fire Width at Builders Opening
- G) 565mm Fire Height at Builders Opening
- H) 117mm Fire Depth into Builders Opening

MANTEL DIMENSIONS

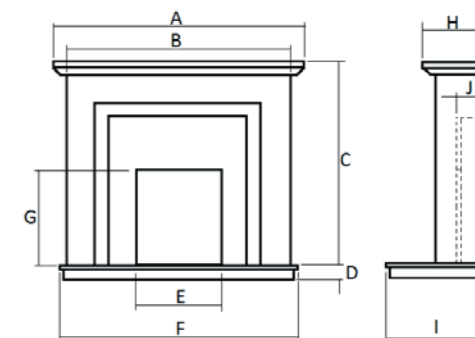

- A) 1370mm
- B) 1278mm
- C) 1095mm
- D) 65mm
- E) 570mm
- F) 1370mm
- G) 590mm
- H) 230mm
- I) 400mm
- J) 75mm

The Panama log fire is a revolutionary product.

This wide format glass fronted gas appliance has the appeal of a European fire but the benefit of fitting into a standard 16" x 22" chimney breast opening. Normally an appliance of this stature would require building work and installation of a new lintel. The Panama has a patent pending installation system which, in conjunction with your new fireplace will provide a much more cost effective solution for this type of product. Talk to your dealer for full details. The Panama comes in slide control as standard.

FLUE OPTIONS

- Brick Chimney
- Pre-Fabricated

CONTROL FUEL BED FUEL

- Slide
- Log
- Natural Gas

STANDARD MANTEL FINISH OPTIONS

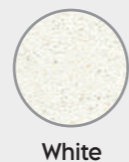

PANAMA TRIM OPTIONS

- Brass/Black
- Satin/Black
- Chrome/Black
- Bl.Nickel/Black
- Anthracite

SLIDE LEVER OPTIONS

- Brass
- Chrome
- Black Nickel
- Black

GAS CONSUMPTION

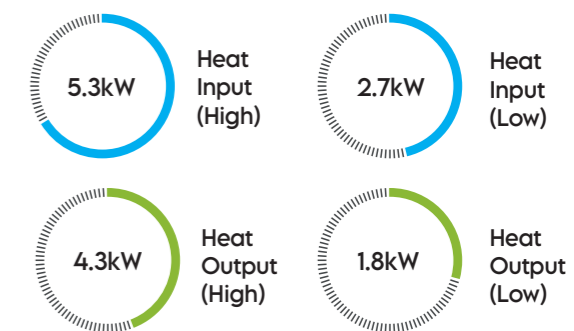

87% EFFICIENCY

Cressida HE



The Cressida HE is a high efficiency glass fronted appliance suitable for Class 1 and Class 2 flues.

The most powerful gas fire in the Wildfire range, with its deep bed and powerful output this appliance provides the ultimate in performance and style.

The flagship Cressida HE is supplied in either manual or slide control. The slide control features the latest patent pending Direct Slide technology.

Remember, once you have chosen your appliance, you can decide how it looks by selecting trim and fret options. See the trim options below and in more detail on page 62.



Cressida HE shown with Creative Contemporary Black Nickel/Black trim. Featured with Elgin & Hall Eliano micro marble surround in white.

FLUE OPTIONS

- Brick Chimney
- Pre-Fabricated

FUEL BED

- Coal

CONTROLS

- Slide
- Manual Electronic

FUEL

- Natural Gas

GAS CONSUMPTION

87% EFFICIENCY



Heat Input (High) 5.3kW
Heat Input (Low) 2.9kW
Heat Output (High) 4.2kW
Heat Output (Low) 2.15kW

DIMENSIONS

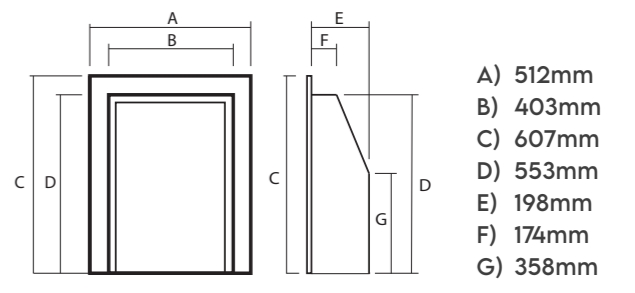

STANDARD TRIM OPTIONS



Contemporary trim includes front bars. Trims can be purchased without front bars. For more details see page 54.

CREATIVE TRIM OPTIONS



PROFILE TRIM OPTIONS



SLIDE LEVER OPTIONS



Pesaro HE



HE

Pesaro HE shown with Chrome Contemporary trim. Featured with Elgin & Hall Eleno micro marble surround in white & grey.

The Pesaro HE is a high efficiency glass fronted appliance suitable for Precast, Class 1 and Class 2 flues.

When the most important factor is heat, then the Pesaro mid-depth high efficiency gas fire will deliver. The fire can be fitted with an additional spacer to reduce the effective depth of the appliance.

The Pesaro HE is available in slide control as standard.

FLUE OPTIONS

- Brick Chimney
- Pre-Fabricated
- Pre-Cast

CONTROL



Slide

FUEL BED



Coal

FUEL



Natural Gas

GAS CONSUMPTION

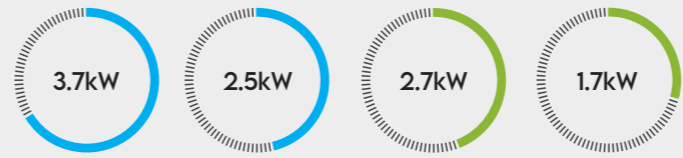

DIMENSIONS

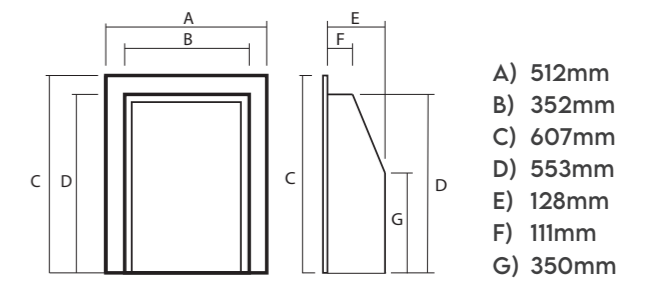

STANDARD TRIM OPTIONS

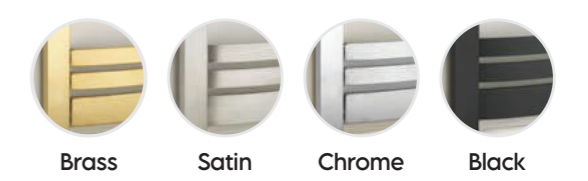

Contemporary trim includes front bars. Trims can be purchased without front bars. For more details see page 54.

CREATIVE TRIM OPTIONS



PROFILE TRIM OPTIONS



SLIDE LEVER OPTIONS



RAVEL 400 HE | (Salvador Suite)



DIMENSIONS

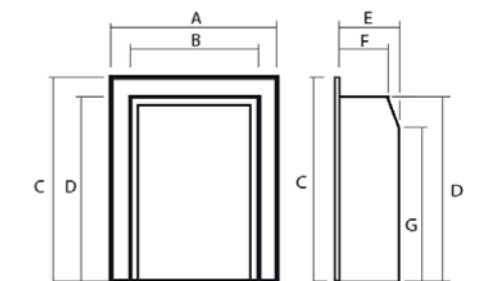

- A) 512mm
- B) 403mm
- C) 610mm (3 sided)
- C) 664mm (4 sided)
- D) 555mm
- E) 197mm
- F) 186mm
- G) 502mm

Also available as 4 sided HIW

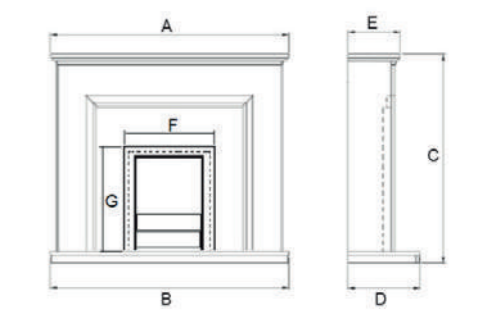

- A) 1370mm
- B) 1370mm
- C) 1160mm
- D) 400mm
- E) 230mm
- F) 512mm
- G) 610mm

RAVEL TRIM OPTIONS

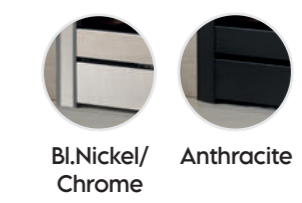

SLIDE LEVER OPTIONS



STANDARD MANTEL FINISH OPTIONS



Ravel HE Log shown with Black Nickel / Chrome trim, installed into the Salvador White Suite

The Ravel 400 HE Log 16"x 22" is a high efficiency glass fronted fire suitable for class 1 and class 2 flues.

The Ravel HE Log is sure to impress, with its under log burners and stunning fuel bed layout. The unique burner system allows the fire to be turned to low whilst still retaining an impressive flame height.

This fire is available with two trim styles, the Black Nickel and Chrome or the striking Anthracite version.

FLUE OPTIONS



CONTROL



FUEL BED

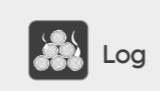

FUEL



GAS CONSUMPTION

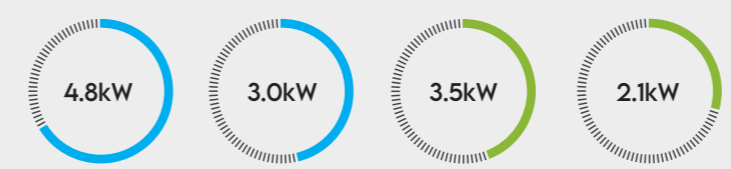

Heat Input (High) Heat Input (Low) Heat Output (High) Heat Output (Low)

RAVEL 400 Inset Stove | (Salvador Suite)



HE

Ravel HE Log shown with Black Nickel / Chrome trim, installed into the Salvador White Suite

DIMENSIONS

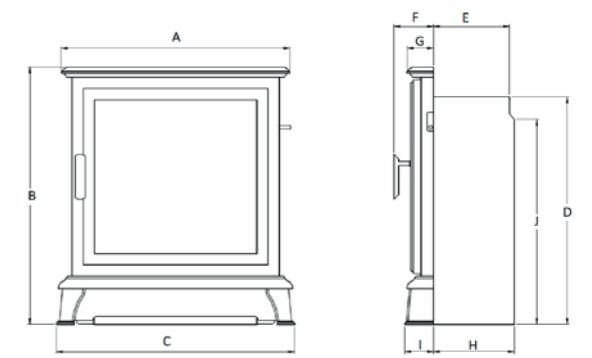

- A) 512mm
- B) 630mm
- C) 584mm
- D) 557mm
- E) 186mm
- F) 97mm
- G) 65mm
- H) 198mm
- I) 70mm
- J) 502mm

STOVE HANDLE OPTIONS



Satin

Black

SLIDE LEVER OPTIONS



Chrome

Black Nickel

Black

Ezi-Grip

FLUE OPTIONS



Brick Chimney



Pre-Fabricated

CONTROL



Slide

FUEL BED



Log

FUEL



Natural Gas

GAS CONSUMPTION

81% EFFICIENCY

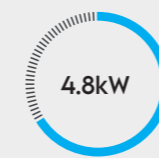

Heat Input (High)

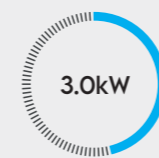

Heat Input (Low)

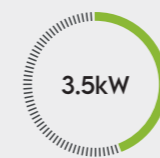

Heat Output (High)

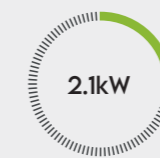

Heat Output (Low)

STANDARD MANTEL FINISH OPTIONS



White

RAVEL 400 HE | (HIW)



DIMENSIONS

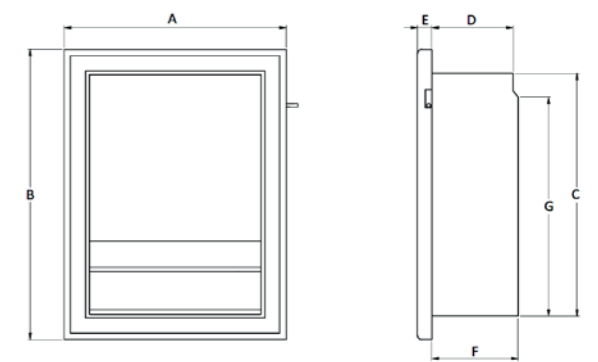

- A) 510mm
- B) 665mm
- C) 556mm
- D) 186mm
- E) 33mm
- F) 198mm
- G) 502mm

RAVEL TRIM OPTIONS



Bl.Nickel/
Chrome

SLIDE LEVER OPTIONS



Chrome



Black
Nickel



Black

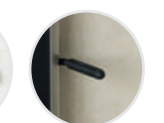

Ezi-Grip

GAS CONSUMPTION



Heat
Input
(High)



Heat
Input
(Low)



Heat
Output
(High)



Heat
Output
(Low)

81% EFFICIENCY

The Ravel 400 can now also be supplied as a slide control hole in the wall product.

The extremely successful black nickel and chrome frame has been used to create this four sided design, allowing a space saving and economical solution for your living room. Offering all of the features and benefits of the Ravel 400 product this log burner will never fail to impress.



Ravel HE Log shown with Black Nickel / Chrome HIW trim.

FLUE OPTIONS



Brick
Chimney



Pre-
Fabricated

CONTROL



Slide

FUEL BED



Log

FUEL



Natural
Gas

RAVEL 400 HE | Balanced Flue



DIMENSIONS

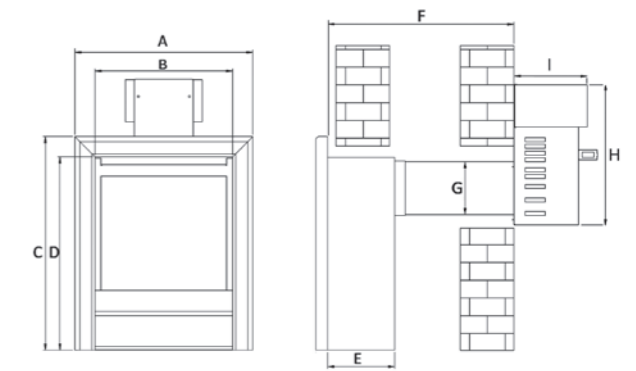

- A) 510mm D) 553mm G) Ø152mm
- B) 394mm E) 197mm H) 400mm
- C) 611mm F) 290-580mm I) 206mm

RAVEL TRIM OPTIONS



Bl.Nickel/Chrome Anthracite Inset Stove (see page 42) HIW (see page 44)

SLIDE LEVER OPTIONS



Chrome Black Nickel Black Ezi-Grip

STANDARD MANTEL FINISH OPTIONS



White

HE

Ravel 400 BF shown with Black Nickel / Chrome trim. Featuring Salvador micromarble fireplace in white (see page 40 for details)

FLUE OPTIONS

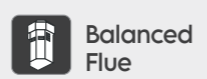

CONTROL



FUEL BED



FUEL



GAS CONSUMPTION

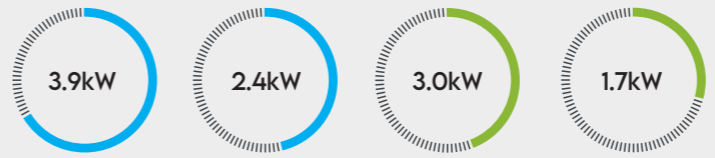

Heat Input (High) Heat Input (Low) Heat Output (High) Heat Output (Low)

The Ravel 400 is now available in balanced flue format. With the same intricately detailed logs and unique underlog burners this appliance is the perfect solution for economic heating in homes without a flue.

The product is available with the two standard Ravel 16" trims in Black Nickel and Chrome or Anthracite but can also be configured to be installed as a hole in the wall (HIW) see page 44, or as an inset stove—see page 42. The Ravel 400BF also employs the same controllability as the conventional flue version, allowing the fire to be turned to a low setting whilst still retaining an impressive flame height.

Thermes

Balanced Flue

“The balanced flue fire that **really** delivers”



The Thermes is our high efficiency balanced flue gas appliance.

If you have no flue or chimney in your home you will need a balanced flue gas fire. The Thermes is a room sealed high efficiency gas fire that really delivers.

This fire flues through an external wall and can be installed in most new or existing fireplaces.

Remember, once you have chosen your appliance, you can decide how it looks by selecting trim and fret options. See the trim options below and in more detail on page 62.

HE Thermes shown with Profile Contemporary Satin/Black trim.

Featured with an Elgin & Hall Roesia surround in white Micro Marble

FLUE OPTIONS



Balanced Flue

FUEL BED



Coal

CONTROLS



Slide



Manual Electronic

FUEL



Natural Gas

GAS CONSUMPTION

86% EFFICIENCY



4.2kW

Heat Input (High)



2.9kW

Heat Input (Low)

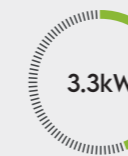

3.3kW

Heat Output (High)

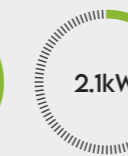

2.1kW

Heat Output (Low)

DIMENSIONS

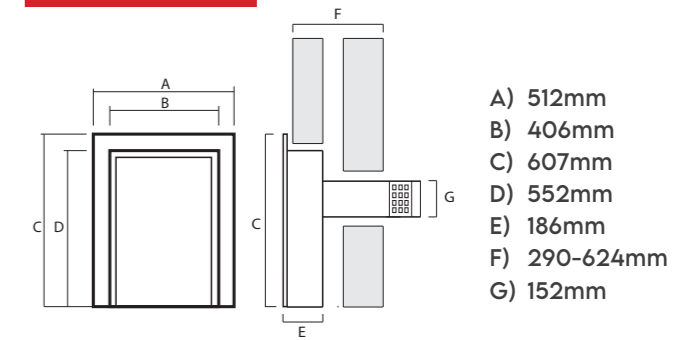

- A) 512mm
- B) 406mm
- C) 607mm
- D) 552mm
- E) 186mm
- F) 290-624mm
- G) 152mm

STANDARD TRIM OPTIONS

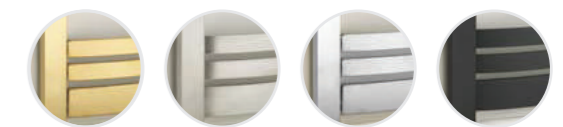

Brass Satin Chrome Black

Contemporary trim includes front bars. Trims can be purchased without front bars. For more details see page 54.

CREATIVE TRIM OPTIONS



Brass/Black Satin/Black Chrome/Black Bl.Nickel/Black

PROFILE TRIM OPTIONS

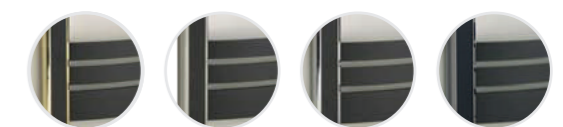

Brass/Black Profile Satin/Black Profile Chrome/Black Profile Bl.Nickel/Black Profile

SLIDE LEVER OPTION



Ezi-Grip

BF960SL

Balanced Flue



Dimensions

TRIM

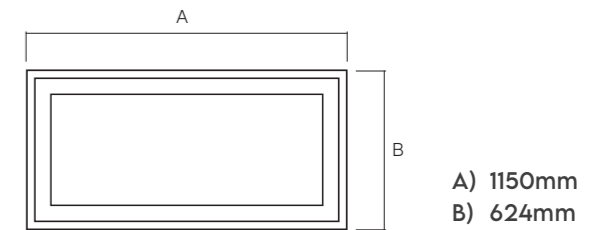

APPLIANCE

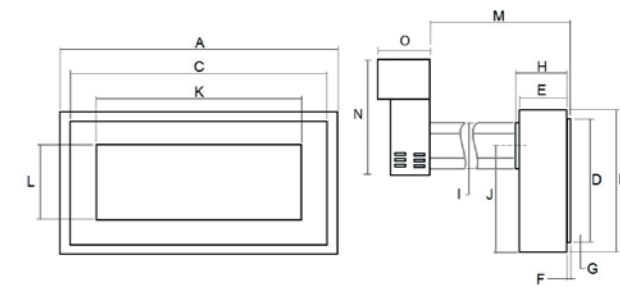

- | | | |
|-----------|----------|------------------|
| A) 1198mm | G) 29mm | M) 270mm - 725mm |
| B) 666mm | H) 183mm | N) 400mm |
| C) 1138mm | I) 151mm | O) 206mm |
| D) 608mm | J) 523mm | |
| E) 174mm | K) 862mm | |
| F) 13mm | L) 332mm | |

GAS CONSUMPTION

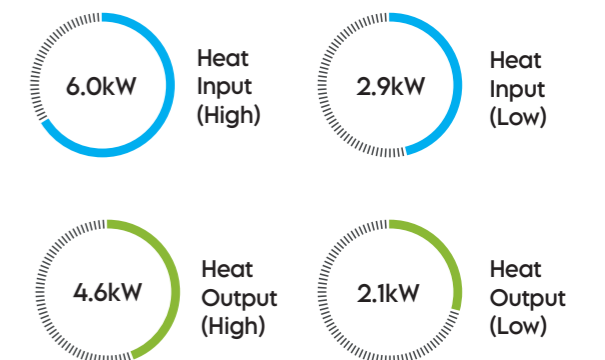

86% EFFICIENCY

The BF960SL balanced flue gas fire is suitable for homes without a chimney.

This versatile and efficient slimline hole in the wall fire can be installed onto any outside wall of the home and generates a contemporary and stylish centrepiece for the room. This appliance can be installed directly into a cavity wall yet provides probably the deepest fuel bed effect for a product of its type. Coupled with a reflective black glass lining, this gas fire delivers the ultimate dancing flame effect and ceramic log layout.

HE

FLUE OPTION



CONTROL



FUEL BED



FUEL



Cavello XE



XE

Cavello XE shown with Brass/Black Contemporary Creative trim. Featuring the Be Modern Isabelle Micro Marble surround in manilla.

The Cavello XE is a realistic open fronted gas fire with a powerful convecting heat exchanger to boost performance.

The Cavello is supplied with the XE System as standard, see page 9 for more details. This convector appliance will produce enough heat to satisfy most of the largest living rooms. It is available in manual and slide control with options of coal and pebble fuel bed effects.

The Wildfire Cavello XE can be supplied with a range of trims to suit the style that you are trying to achieve. See full trim options on page 62.

FLUE OPTIONS



FUEL



CONTROLS



FUEL BEDS



GAS CONSUMPTION

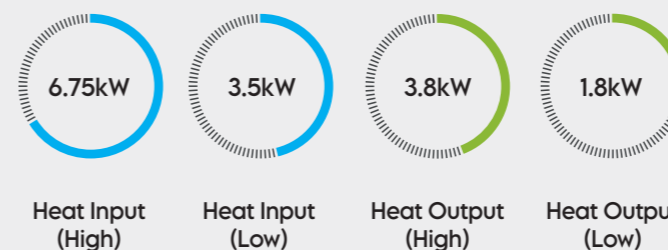

DIMENSIONS

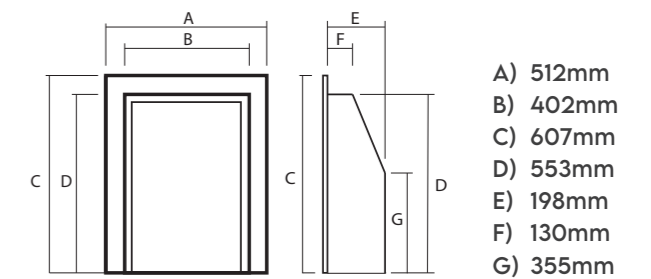

STANDARD TRIM OPTIONS

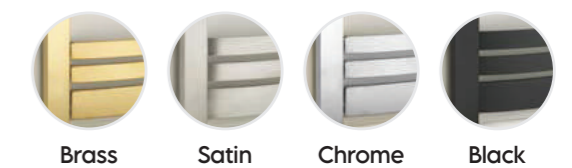

Contemporary trim includes front bars. Trims can be purchased without front bars. For more details see page 54.

CREATIVE TRIM OPTIONS



PROFILE TRIM OPTIONS



SLIDE LEVER OPTIONS

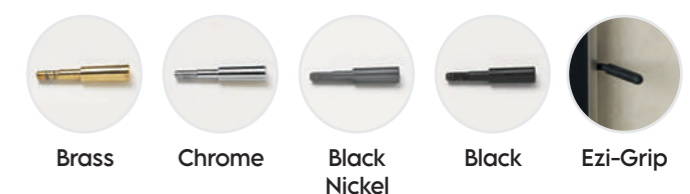

Montese | (Cadiz Suite)



XE

Available as XE model with canopy see page 7 for further information.

The Montese shown with Cadiz suite in white/Grey. Also shown in all white (inset). Cadiz suite available with or without lights.



The Montese is a stunning fire that will enhance any living room.

The Montese is an authentic looking coal effect gas fire, where realism is the most important factor.

By utilising the broad range of trims that Wildfire provides, you can choose the mood of your room from contemporary to traditional. It is available with pebble and coal fuel bed options and offers an impressive radiant heat output.

The Wildfire Montese is available in manual and slide control. See page 62 for full trim specifications.

FLUE OPTIONS

- Brick Chimney
- Pre-Fabricated
- Pre-Cast

CONTROLS

- Slide
- Manual

STANDARD MANTEL FINISH OPTIONS

White

Grey

Cadiz suite available with or without grey inner border.

FUEL

- Natural Gas

FUEL BEDS

- Coal
- Pebble

DIMENSIONS

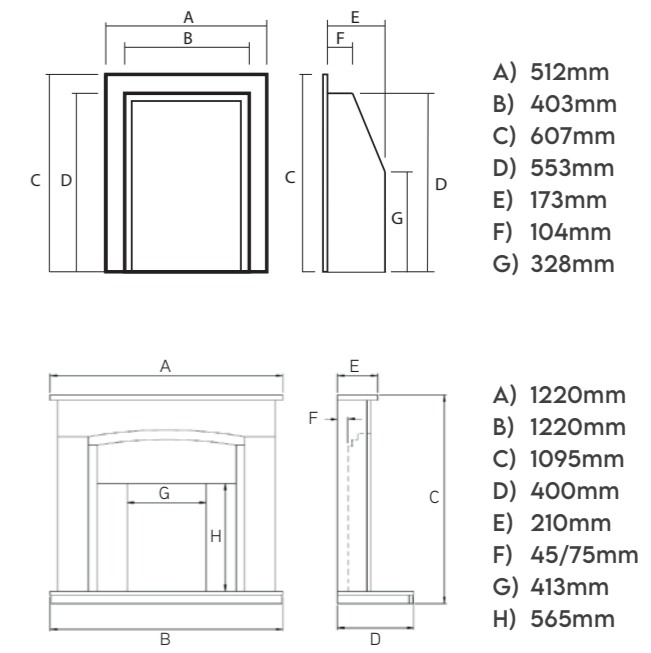

STANDARD TRIM OPTIONS

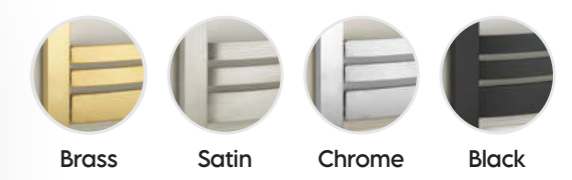

Contemporary trim includes front bars. Trims can be purchased without front bars. For more details see page 54.

CREATIVE TRIM OPTIONS



PROFILE TRIM OPTIONS

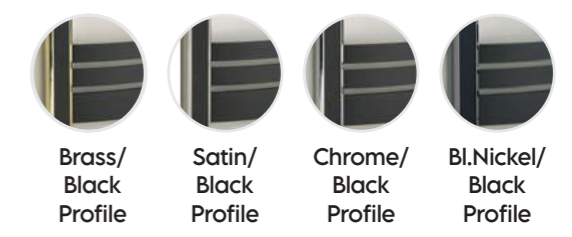

GAS CONSUMPTION

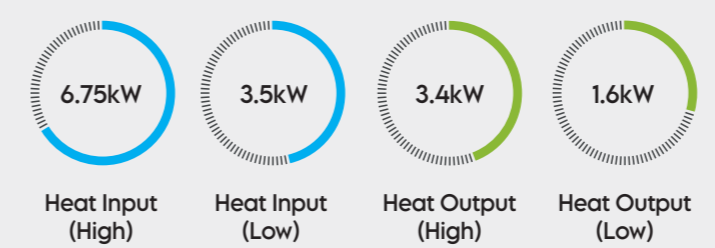

ENERGY EFFICIENCY CLASS F

SLIDE LEVER OPTIONS

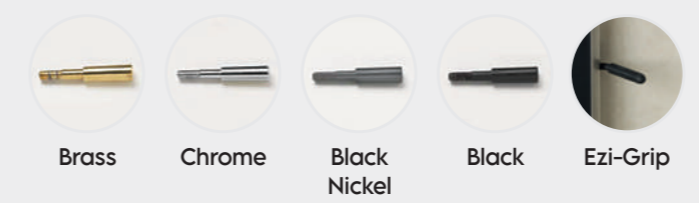

Ceralis | (Salerno Suite)



The Ceralis shown with profile contemporary brass/black trim. The Salerno 42" mantel in all white. Also available as 48". Also available in white/grey.



Available as XE model with canopy see page 9 for further information.

The Ceralis is a powerful slimline appliance that will fit into all flue types. A spacer is available to enable it to be fitted into shallow precast flues.

The realistic fuel bed boasts a powerful flame picture for its size making the Wildfire Ceralis the obvious option when the flue available limits your choice of fire.

The Ceralis is available in manual and slide control with coal and pebble fuel bed options. The slimline fire is a stunning appliance which makes it the first choice for your precast flue. For full trim options see page 62.

FLUE OPTIONS

- Brick Chimney
- Pre-Fabricated
- Pre-Cast

FUEL

- Natural Gas

CONTROLS

- Slide
- Manual

FUEL BEDS

- Coal
- Pebble

STANDARD MANTEL FINISH OPTIONS

White

Grey*

Available with grey inner border. See similar detail on the Cadiz suite - page 48
Grey border option not available on 42"

DIMENSIONS

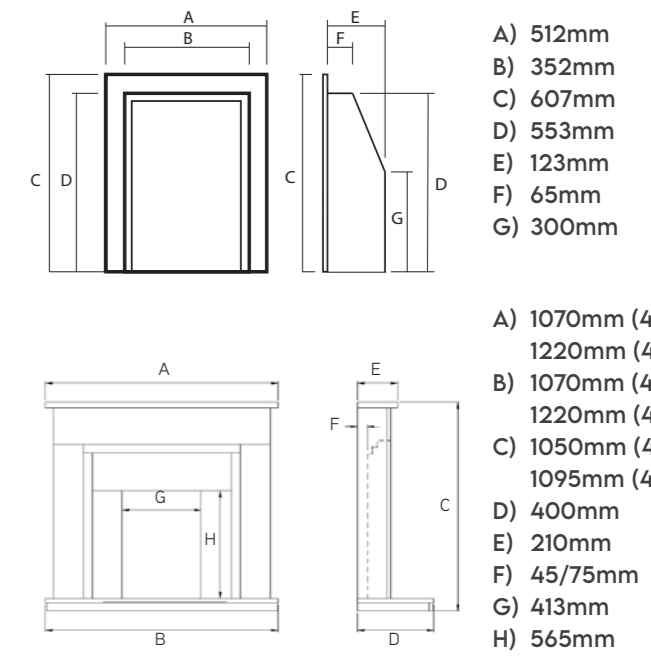

STANDARD TRIM OPTIONS

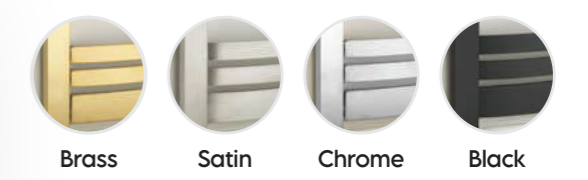

Front bars are optional. For more details see page 54

CREATIVE TRIM OPTIONS



PROFILE TRIM OPTIONS



GAS CONSUMPTION

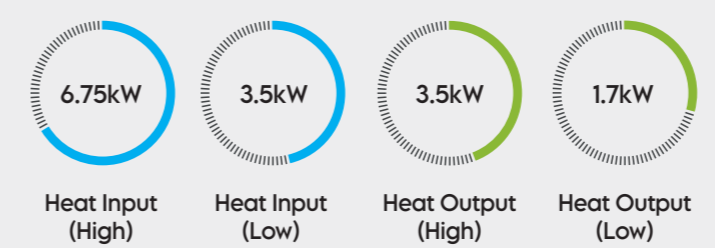

SLIDE LEVER OPTIONS

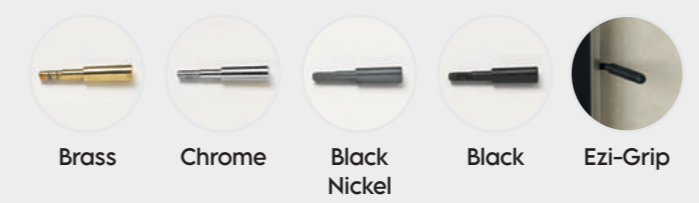

Ellipsis



NOTE: GRANITE SLIPS **NOT** INCLUDED



The Ellipsis 'Hole in the wall' with Chrome/Black trim. Open fronted in pebble (inset)

This beautifully styled hole in the wall appliance produces a powerful output.

Its warmth will transform your living environment. The Ellipsis is suitable for Class 1 and Class 2 flue types and is available in Coal or Pebble**.

The Ellipsis is available in open fronted or glass fronted HE format. The Ellipsis open fronted has a pebble option. This product is only available as manual control.

The Wildfire Ellipsis combines style, efficiency and space saving to provide the ultimate solution for an open fronted gas or glass fronted fire. If you are looking for realism coupled with powerful heat whilst retaining efficiency then this is the product for you.

FLUE OPTIONS

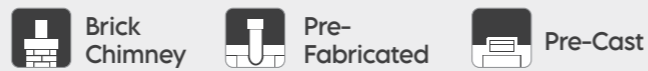

CONTROLS



FUEL



FUEL BEDS



**Open fronted only

ELLIPSIS TRIM OPTIONS



4 Sided Satin/Black

4 Sided Chrome/Black

Satin/Black

Chrome/Black

Also available in 3 sided for hearth mounted version

Dimensions

OPEN FRONTED

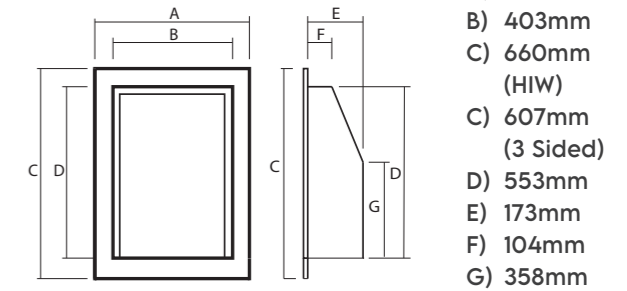

GLASS FRONTED

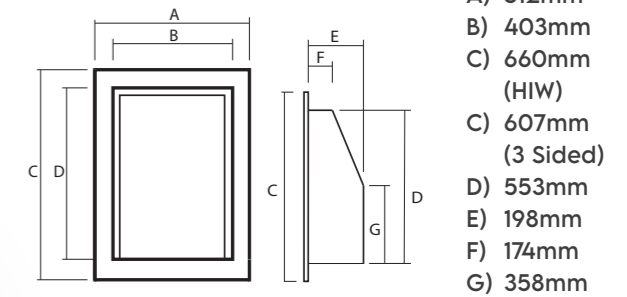

BALANCED FLUE

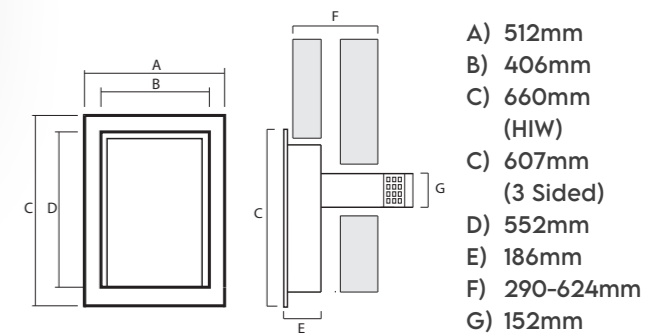

GAS CONSUMPTION

For inputs and outputs and efficiency classes refer to the relevant pages as below:

OPEN FRONTED (REFER TO MONTESE - PAGE 54)

GLASS FRONTED (REFER TO CRESSIDA - PAGE 36)

BALANCED FLUE (REFER TO THERMES - PAGE 48)

RAVEL Gas Stove



The Ravel Stove is a stunning addition to any open fireplace. Based on the proven under-log burner system of the highly successful Ravel gas fire.

This gas stove version features crisp and clean lines only possible with the light weight aluminium extrusion employed in this design. Suitable for use with Class 1, Class 2 and precast flues.*

The unique burner system allows the fire to be turned to low whilst still retaining an impressive flame effect.



Ravel Gas Stove shown inset with black handle and control lever. Available as optional extras.

DIMENSIONS

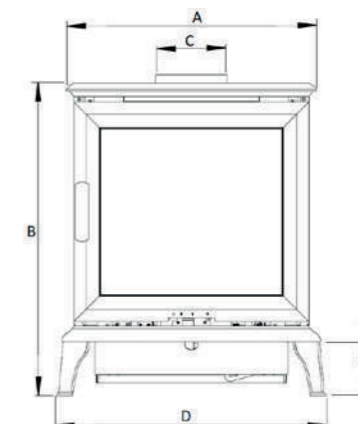

- A) 464mm
- B) 584mm
- C) 127mm
- D) 502mm
- E) 100mm
- F) 289mm
- G) 315mm
- H) 67mm
- I) 515mm

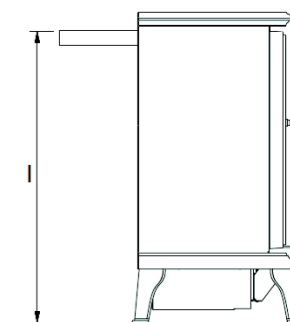
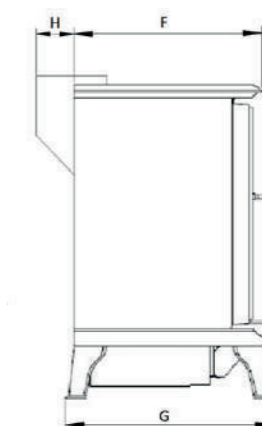

*Precast flue kit is ordered separately.

GAS CONSUMPTION

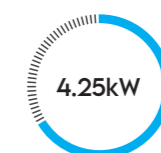

Heat Input (High)

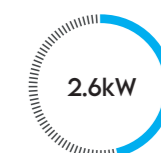

Heat Input (Low)



Heat Output (High)

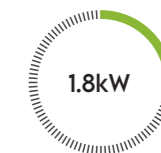

Heat Output (Low)

82% EFFICIENCY

FLUE OPTIONS



Brick Chimney



Pre-Fabricated



Pre-Cast

WATCH VIDEO



Scan QR Code

CONTROL



Slide

FUEL BED



Log

FUEL



Natural Gas

Trim Options

Choose the trim and fret options from the selection on this page. The Standard and Creative trim and fret options will fit **MOST** of the products in this brochure. The Ellipsis trim will fit manual control fires only. For further fret options consult your retailer.

SLIDE LEVER OPTIONS

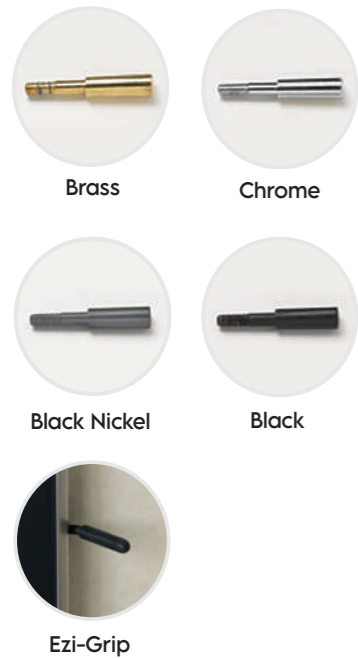

STANDARD TRIM OPTIONS



CREATIVE TRIM OPTIONS

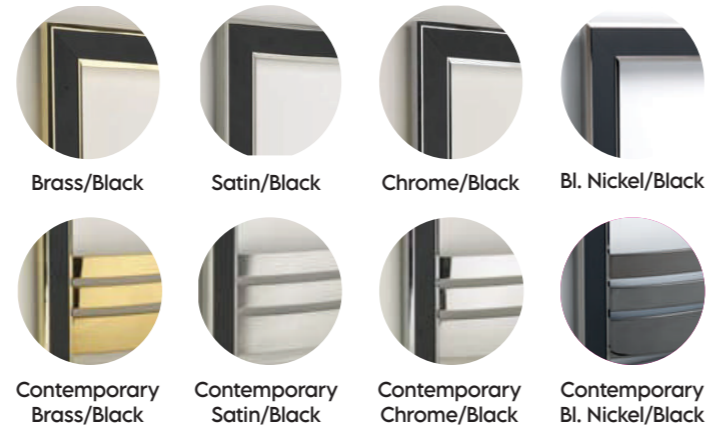

PROFILE TRIM OPTIONS

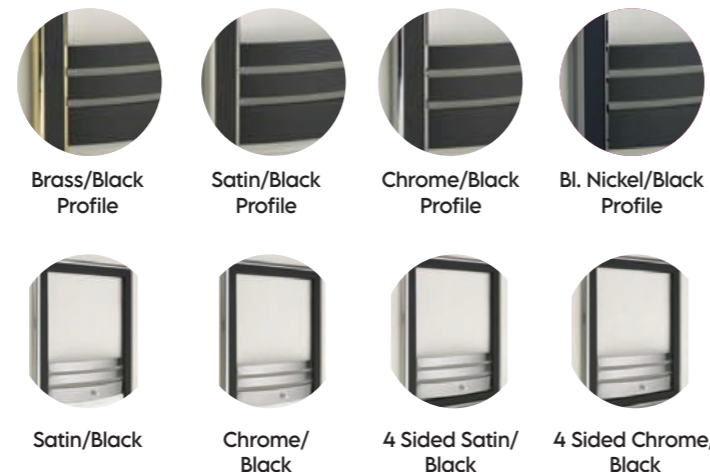

ELLIPSIS TRIM OPTIONS



Ellipsis trim only suitable for manual control appliances

PANAMA TRIM OPTIONS



RAVEL TRIM OPTIONS

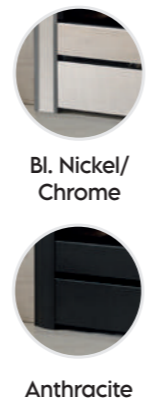

Technical Information

Use the chart below to quickly check the options available for each product contained in this brochure. You will also find the flue types which products can be installed into. For further information consult the manufacturer's installation instructions or ask your local retailer for further advice.

PAGE NO.	FIRES	COAL OPTION	PEBBLE OPTION	LOG OPTION	MANUAL CONTROL	SLIDE CONTROL	PRE-CAST FLUE	CLASS II FLUE	CLASS I FLUE	BALANCED FLUE	XE INCLUDED	XE OPTIONAL	HE
10-11	RAVEL MW 1500			✓		✓				✓			✓
12-13	RAVEL MW 1720			✓		✓				✓			✓
14-15	HE900 (STD & PCF)			✓		✓	✓	✓	✓				✓
16-17	HE950L (STD & PCF)			✓		✓	✓	✓	✓				✓
18-23	RAVEL 600			✓		✓		✓	✓				✓
24-29	RAVEL 800			✓		✓		✓	✓				✓
30-33	RAVEL 750			✓		✓		✓	✓				✓
34-35	PANAMA			✓		✓		✓	✓				✓
36-37	CRESSIDA HE	✓			✓	✓		✓	✓				✓
38-39	PESARO HE	✓				✓	✓	✓	✓				✓
40-45	RAVEL HE			✓		✓		✓	✓				✓
46-47	RAVEL BF			✓		✓				✓			✓
48-49	THERMES BF	✓			✓	✓				✓			✓
50-51	BF960SL			✓		✓				✓			✓
52-53	CAVELLO XE	✓	✓		✓	✓		✓	✓		✓		
54-55	MONTESE	✓	✓		✓	✓	✓	✓	✓			✓	
56-57	CERALIS	✓	✓		✓	✓	✓	✓	✓			✓	
58-59	ELLIPSIS HIW	✓	✓*		✓			✓	✓			✓	✓**
60-61	RAVEL GAS STOVE			✓		✓	✓	✓	✓				✓

Some things you need to know



Electric Fireplace Suites

All of our electric appliances provide up to 2kW of instantaneous heat. At the push of a button, or from a programmed timer, this clean convected heat will power warmth into your room whenever you need it.

A mesmerising flame effect completes these beautiful products. With stunning log arrangements and a choice of three levels of flame control and up to five brightness/intensity levels. The vibrant flame effects provide that feeling of comfort even when the heat is not switched on. The flame effect system is a safe convenient and efficient design which uses only LED technology to ensure that running costs in flame only mode are extremely low.

The Wildfire range of suites couple this electric fire technology with exquisite micro marble fireplaces. Available in a range of colours (see pages 70 & 71) these suites all allow a flat to wall installation*

*The Panama E22 and Ravel E16 installed in the Salvador suite require a spacer frame (supplied separately) to allow flat to wall installation. If no spacer is required for this suite then a 65mm recess for the width and height of the appliance is required.

The distinguishing feature of a flame effect electric fire is the ability to provide a 'feel warm' comfort level with its' mesmerising glow at any time of the year. An energy efficient way to produce a stunning effect with minimal running costs. The instantaneous heat can be called upon on those colder evenings when its just not practical or cost efficient to turn on the central heating.



What control options are available?

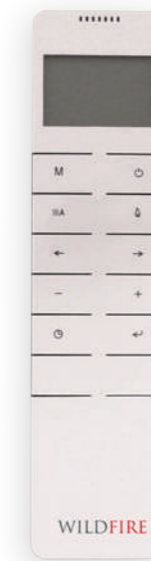

The multifunction remote control handset provides ultimate controllability for your electric appliance. From 'Normal' operating mode where the appliance will run continually until the required temperature is set, to daily or weekly timer settings to give you complete control over the heating function.

A countdown timer is also included so the unit can be automatically be powered down after a predetermined length of time.

This beautifully styled remote features an internal thermostat to ensure it senses the right temperature in the room. An LCD display features all of the control functions available including flame setting and flame intensity.



We guarantee* our electric fire products for a period of 1 year from installation and our customer service staff are always on hand to help you with any query you may have with your product.

Our 1 year guarantee* is managed directly by Wildfire through our extensive network of service centres throughout the UK. Choose Wildfire for style, performance, reliability, value and peace of mind.

HE 900E | (Avellino Suite)



The HE900E Avellino is a 52" flat to wall marble electric fireplace suite.

This fully electronic remote control fireplace offers 7 day thermostatic operation. The suite is available in all white or white with a distinctive grey highlight. A variety of flame effects provide a great solution to suit the mood for the day.

CONTROL



Remote

FUEL BED



Log

FUEL



Electric

STANDARD MANTEL FINISH OPTIONS



White



Grey

Available with grey inner border - see similar detail on the Seville Suite - page 12.

DIMENSIONS

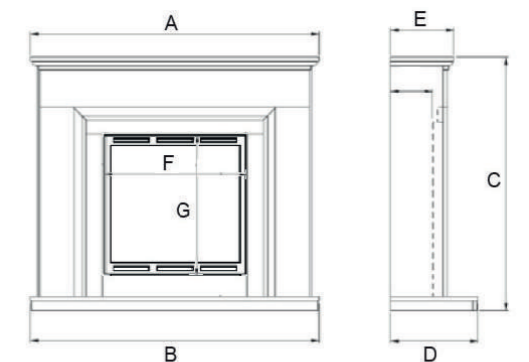

- A) 1320mm
- B) 1320mm
- C) 1159mm
- D) 400mm
- E) 235mm
- F) 660mm
- G) 740mm

For full technical and dimensional specifications refer to pages 74 and 75.

HE 950LE | (Seville Suite)



The HE950LE Seville is a 52" flat to wall marble electric fireplace suite.

This incredible fireplace has been launched to complement the already successful, multi award winning HE950L Seville gas suite. It is available in the same flawless micro marble colour options, white or white with grey slip highlights. The appliance is fully thermostatic and has timers to allow heating to take place at the appropriate times.

CONTROL



Remote

FUEL BED



Log

FUEL



Electric

STANDARD MANTEL FINISH OPTIONS



White



Grey

Available with grey inner border - see similar detail on the Seville Suite - page 12.

DIMENSIONS

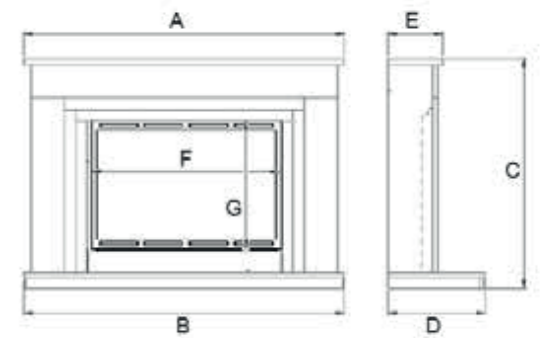

- A) 1320mm
- B) 1320mm
- C) 967mm
- D) 400mm
- E) 235mm
- F) 800mm
- G) 520mm

For full technical and dimensional specifications refer to pages 74 and 75.

Panama E22 | (Salvador Suite)



The Panama E22 Salvador is a 54" micro marble electric fireplace suite, available in all white.

The Panama E22 can be supplied with numerous trim options, from the black anthracite or the two tone anodised range featuring brass, satin, chrome, black nickel & the new black nickel/chrome effect. The appliance is a fully electronic remote control fireplace offering a 7 day thermostatic operation. A variety of flame effects can be selected using the digital remote control, along with a whole range of other programmable features. For full information on the remote system refer to pages 74 and 75.

This product can be installed onto a flat wall if a 65mm spacer (available separately) is fitted. Alternatively a recess behind the fireplace can be made to accept the appliance rear section, talk to your retailer for further details.

CONTROL FUEL BED FUEL



STANDARD MANTEL FINISH OPTIONS

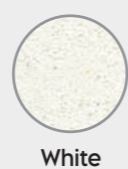

PANAMA TRIM OPTIONS

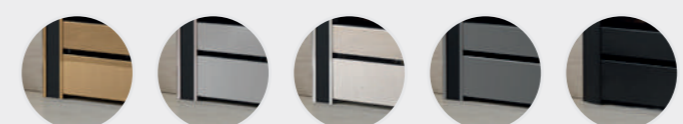

Brass/Black Satin/Black Chrome/Black Bl.Nickel/Black Anthracite

DIMENSIONS

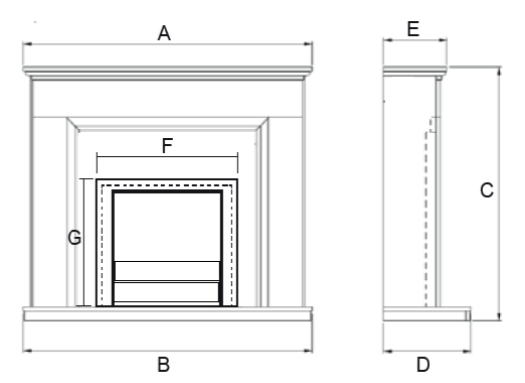

A) 1370mm	D) 400mm	G) 611mm
B) 1370mm	E) 230mm	
C) 1160mm	F) 614mm	

For full technical and dimensional specifications refer to pages 74 and 75.

RAVEL E16

(Salvador Suite)



Ravel shown with Contemporary BI.Nickel/Chrome trim.

Featured with a Wildfire Salvador 54" surround in Manilla Micro Marble

The Ravel E16 Salvador is a 54" micro marble electric fireplace suite, available in all white.

The Ravel E16 can be supplied with either a black anthracite or a black nickel and chrome trim option. The fireplace can be installed onto a flat wall if a spacer (available separately) is fitted. Alternatively a recess behind the fireplace can be made to accept the appliance rear section, talk to your retailer for further details. The appliance is a fully electronic remote control fireplace offering a 7 day thermostatic operation. A variety of flame effects can be selected using the digital remote control, along with a whole range of other programmable features.

CONTROL



Remote

FUEL BED



Log

FUEL



Electric

RAVEL TRIM OPTIONS

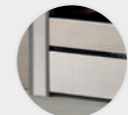

BI.Nickel/Chrome

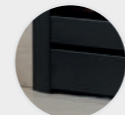

Anthracite

STANDARD MANTEL FINISH OPTIONS



White

DIMENSIONS

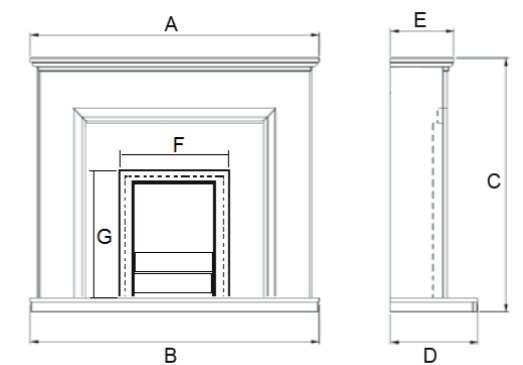

- | | | |
|-----------|----------|----------|
| A) 1370mm | D) 400mm | G) 611mm |
| B) 1370mm | E) 230mm | |
| C) 1160mm | F) 512mm | |

For full technical and dimensional specifications refer to pages 74 and 75.

Marble and Trim options electrical

	AVELLINO HE900E	SEVILLE HE950LE	SALVADOR PANAMA E22	SALVADOR E16
MARBLE COLOURS	W / WG	W / WG	W	W
TRIM OPTION	As pictured	As pictured	Br / Sa / Ch / An / BN	Br / Sa / Ch / An / BN
REMOTE CONTROL	Yes	Yes	Yes	Yes
THERMOSTATIC	Yes	Yes	Yes	Yes
PROGRAMMABLE TIMER	Yes	Yes	Yes	Yes
FLAME COLOUR SETTINGS	3	3	3	3
FLAME INTENSITY SETTINGS	5	5	5	5
MAX HEATER OUTPUT	2kW	2kW	2kW	2kW
SPACER OPTION FOR FLAT-WALL FIX	N/A	N/A	Yes	Yes

KEY Marble Colours: W: White WG: White with Grey Slips
 Trim Options: Br: Brass/Black Sa: Satin/Black Ch: Chrome Black An: Anthracite BN: Black Nickel/Black

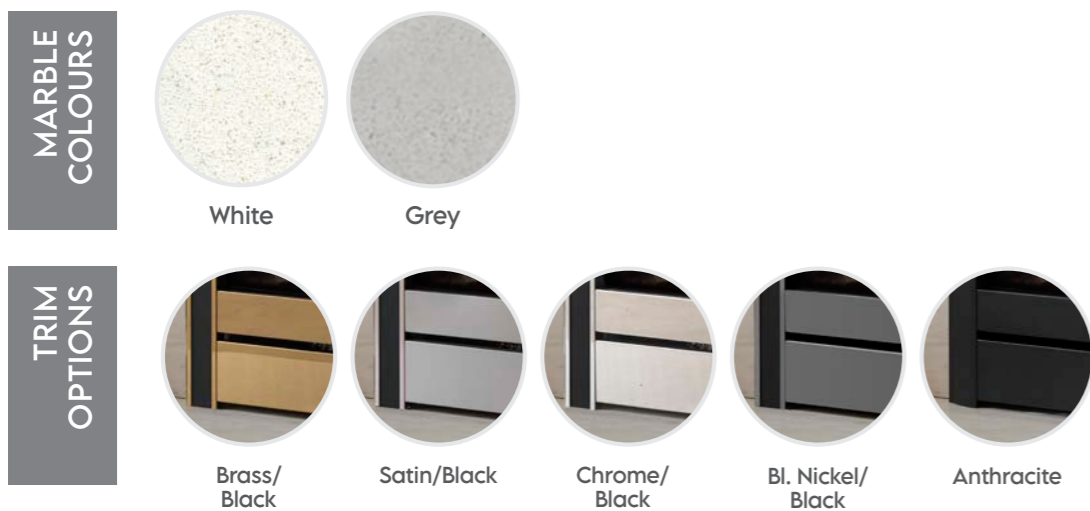

Marble and Trim options electrical

PAGE NO.	ELECTRIC FIREPLACE SUITE	HEARTH WIDTH	HEARTH DEPTH	SHELF WIDTH	SHELF DEPTH	OVERALL HEIGHT
66-67	AVELLINO HE900E	1320mm	400mm	1320mm	290mm	1159mm
68-69	SEVILLE HE950LE	1320mm	400mm	1320mm	290mm	967mm
70-71	SALVADOR PANAMA E22	1370mm	400mm	1370mm	230mm	1160mm
72-73	SALVADOR RAVEL E16	1370mm	400mm	1370mm	230mm	1160mm





Sales Enquiries

sales@hearthproducts.co.uk

Technical Enquiries

customerservice@hearthproducts.co.uk

Telephone

01785 225401

Fax

01785 225501

HEARTH PRODUCTS

Hearth Products Ltd, Unit 14 Brindley Close,
Tollgate Industrial Estate, Stafford ST16 3SU



www.wildfiregas.co.uk
www.wildfireelectric.co.uk

Scan the QR code with your mobile device
to be directed to the Wildfire website.

UK
CA

UK
NI



HHIC | HEATING & HOTWATER
INDUSTRY COUNCIL

